

MIXIT

All-in-one mixing loop



1. Mixing loops made simple	4	Terminal connections overview	47
Features	5	8. Operating the product	48
Temperature control	5	Operating panel for MIXIT	48
Controlling MIXIT	5	Starting up the system	49
Applications	5	Temporary heating	51
Compatibility	5	Setting up the product using Grundfos GO	
2. Performance range	6	Remote	51
Performance curves	8	Warnings and alarms	51
3. Guide to selection and sizing	13	Firmware updates	51
Valve selection using performance range curves	13	9. Operating conditions	52
Valve sizing based on calculations	13	Location	52
Sizing tool for MIXIT	13	Maximum distance between MIXIT and the	
Step-by-step valve sizing guide	14	pump	52
4. System applications	16	Minimum space requirements	52
System integration	16	Ambient conditions	52
Distribution circuits	16	Maximum operating pressure	52
MIXIT in a radiator heating system	20	Pumped liquids	52
MIXIT in a underfloor heating system	22	Radio communication	52
MIXIT in an air handling unit system	24	10. Technical data	53
MIXIT in a cooling system	27	Type key	53
MIXIT in a combined system (heating &		Cable requirements	53
cooling)	29	Electrical data	53
5. Components	31	Inputs and outputs	53
Ball valve	33	Classes	54
Non-return valve	34	Sound pressure level	54
Seats	34	Actuator	54
Sensors	34	Sensor data	55
6. Functions overview	35	Valve	57
Temperature controller	36	11. Dimensions	60
Underfloor overheat protection	37	12. Accessories	63
Heating coil preheat and frost protection	37	Insulating shells for heating systems	63
Frost protection for cooling	37	Non-return valve	63
Frost protection for combined heating and		Outdoor temperature sensors	63
cooling	37	Temperature sensors	64
Pump control modes	37	Temperature protection switch	64
Weather curve	37	Thread-thread adapters	65
Eco schedule	38	Thread-flange adapters	66
Warm-weather shutdown	38	Flange-flange adapters	67
Pressure independence	38	13. Product numbers	69
Supply flow limit	38	MIXIT valve unit	69
Return temperature limit	38	Upgrades	69
Thermal power limit	38	MAGNA3 single-head pumps	70
Differential temperature limit	38	MAGNA3 twin-head pumps	70
Supply source setpoint	38	MAGNA3 single-head pumps for the German	
Energy monitor	40	market	71
Grundfos BuildingConnect	43	MAGNA3 twin-head pumps for the German	
Fieldbus integration	43	market	71
7. Installation	44	TPE3 single-head pumps	72
Insulating shells	44	TPE3 twin-head pumps	72
Electrical installation	45	14. Technical terms	73
Orientations	46		

15. Grundfos Product Center75

1. Mixing loops made simple

Grundfos MIXIT is an all-in-one mixing loop for heating and cooling systems.

MIXIT is controlled by a built-in actuator and controller and it offers the following:

- a uniquely designed valve for precise flow-temperature control due to real-time sensor measurements, even at low flow, ensuring stable control
- modified equal percentage characteristic for linear heat power regulation
- easy setup and a completely integrated temperature control solution tailored to your specific application
- flexible offerings in both applications, and features designed to accommodate your needs
- one connection for all data points on the system, pump and MIXIT unit.

A complete mixing loop with only two components

With MIXIT the complexity of the traditional mixing loop is vastly reduced, as MIXIT allows you to build a complete mixing loop with only two components:

1. MIXIT, a highly intelligent valve unit with integrated non-return valve (threaded versions), actuator and sensors
2. MAGNA3, a best-in-class circulator pump or TPE3, single-stage pump.

This makes designing, installing and operating mixing loops incredibly simple and easy. Also, because MIXIT is designed to communicate with the MAGNA3/TPE3 pump via Grundfos GLoWPAN radio signal, no additional wiring or control unit is needed.

In traditional mixing loops, the components needed for a mixing loop are supplied from different vendors. With MIXIT you get single point of warranty and competent technical support for the entire MIXIT system.

Traditional mixing loop vs. the MIXIT system

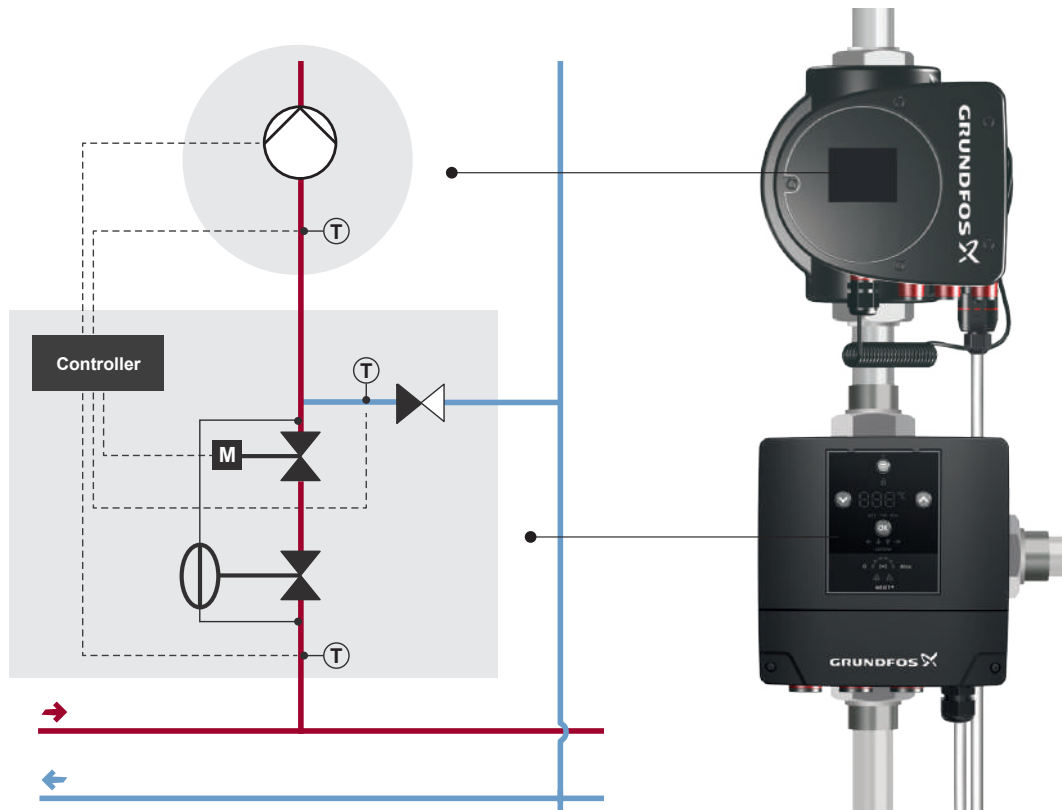

Left: Traditional setup. Right: MIXIT system.

TM071467

Features

- All-in-one, plug-and-play solution eliminating any uncertainties found in a traditional mixing-loop setup.
- Integrated actuator and controller.
- Built-in temperature and flow sensors.
- Pressure independent control valve with balancing function.
- Integrated, removable non-return valve in threaded versions. Non-return valves are available as an accessory for flange versions.
- Valve and pump settings to match your application, ensuring a more effective application control.
- Fast and simple installation and setup.
- Intuitive and simple operating panel.
- Easy configuration with the Grundfos GO Remote app.
- Built-in fieldbus (BACnet, Modbus or GENibus) for easy integration into building management systems (BMS).
- Insulating shells for heating systems according to ENeV supplied with the product.

As MIXIT is a pre-fabricated, complete mixing loop with integrated control functions, only two power cables are required for the MIXIT system to work. The compact design ensures a maximum utilisation of space and a tidy and compact installation.

The MIXIT system can operate as follows:

- as a standalone mixing loop in buildings without any additional equipment
- as a subsystem in larger building controlled by a BMS system.

Related information

[Non-return valve](#)

[Sensors](#)

[Operating panel for MIXIT](#)

Temperature control

The built-in temperature control controls the secondary flow temperature. The controller adjusts the position of the valve according to the setpoint and measured temperatures, and it acts according to the application. The setpoint can be set on the operating panel, in Grundfos GO Remote or via fieldbus.

In radiator and underfloor heating systems the controller will control the mixed flow temperature.

In heating-coil applications it will control the air temperature leaving the heating coil. The temperature is measured by an external sensor, which is available as an accessory.

In cooling applications the controller will control the mixed flow temperature.

Related information

[Temperature sensors](#)

Controlling MIXIT

Setting up and controlling a mixing loop have never been easier. This is done via MIXIT's operating panel and Grundfos GO Remote. With Grundfos GO Remote you can do the following:

- Configure whether MIXIT must operate as a two- or three-way valve.
- Define the application type, allowing you to activate settings, which are typically found beneficial in the given system.
- Set functions such as weather curve, primary flow balancing and thermal power limit.
- Monitor the operating status.
- Schedule an operating pattern and set warm-weather shutdown.
- Unlock and download upgrades.

Via wireless communication, the MIXIT valve unit takes control over the pump, which means that no additional wiring between MIXIT and the pump is needed.

Applications

MIXIT is a control valve with actuator and built-in unit control.

Besides a control valve, MIXIT also includes sensors and an integrated non-return valve (only threaded versions). The actuator is incorporated in a control box together with a control unit which controls both the actuator and the pump.

MIXIT can be used in mixing loops in all heating and cooling systems where there is a need to control the flow temperature, such as radiator heating, underfloor heating, air handling units and cooling applications.

MIXIT is perfect for new installations or complete renovations in commercial buildings as replacement for traditional mixing loops.

MIXIT can either operate as a stand-alone system or as a subsystem in installations controlled by a BMS system.

Compatibility

MIXIT is compatible with MAGNA3 (D) model D and later pumps with production code from 1943 (YYWW) and onwards.

MIXIT is compatible with TPE3 (D) pumps.

Multi-pump mode

MIXIT supports pumps operating with the multi-pump function enabled for the control of single-head pumps connected in parallel and twin-head pumps without the use of external controllers.

The multi-pump system must be set via a selected pump, i.e. the master pump (first selected pump).

2. Performance range

MIXIT	B-port orientation	Connection	G [inch]	PN	K _{vs} value, A and B port [m ³ /h] ¹⁾	Minimum settable flow limit [m ³ /h] ²⁾
DN 25-6.3	Left	Threaded	G 1 1/2	PN 10	6.3	0.3
DN 25-6.3	Right	Threaded	G 1 1/2	PN 10	6.3	0.3
DN 25-10	Left	Threaded	G 1 1/2	PN 10	10	0.5
DN 25-10	Right	Threaded	G 1 1/2	PN 10	10	0.5
DN 32-16	Left	Threaded	G 2	PN 10	16	0.8
DN 32-16	Right	Threaded	G 2	PN 10	16	0.8
DN 32-16	Left	Flange		PN 6/10	16	0.8
DN 32-16	Right	Flange		PN 6/10	16	0.8
DN 40-25	Left	Flange		PN 6/10	25	1.3
DN 40-25	Right	Flange		PN 6/10	25	1.3
DN 50-40	Left	Flange		PN 6/10	40	2
DN 50-40	Right	Flange		PN 6/10	40	2

¹⁾ The K_{vs} value represents the water in m³/h at a differential pressure of 1 bar from port A to AB.

²⁾ The DYNAMIC upgrade is required to set a flow limit.

B-port orientation

All MIXIT valve units are available with either right or left B-port orientation.

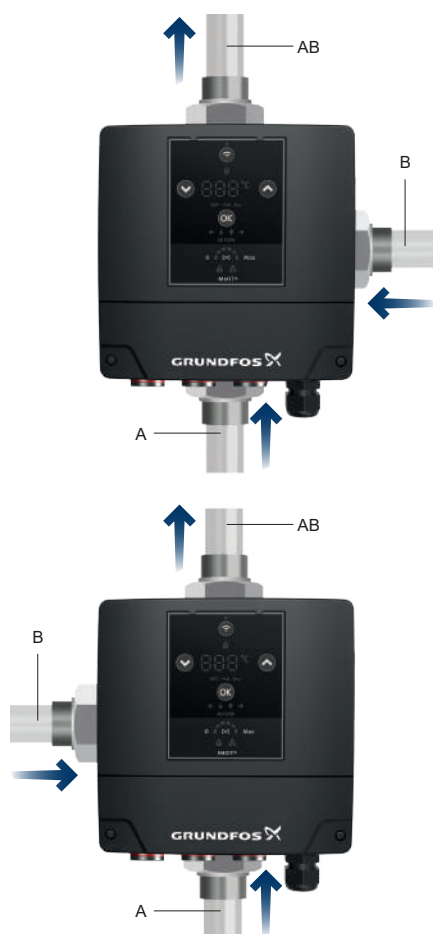

TM071426

MIXIT B-port orientations with indication of flow direction

Applicable MAGNA3 pumps

The pump size best suited for your application is determined based on the desired secondary flow. MIXIT is typically coupled with the MAGNA3 variants listed below.

Single-head pumps

- 25-40/60/80/100/120
- 32-40/60/80/100/120
- 32-40/60/80/100/120 F
- 40-40/60/80/100/120/150/180 F
- 50-40/60/80/100/120/150/180 F
- 65-40/60/80/100/120/150 F

Twin-head pumps

- 32-40/60/80/100
- 32-40/60/80/100/120 F
- 40-40/60/80/100/120/150/180 F
- 50-40/60/80/100/120/150/180 F
- 65-40/60/80/100/120/150 F

Applicable TPE3 pumps

The pump size best suited for your application is determined based on the desired secondary flow.

MIXIT is typically coupled with the TPE3 variants listed below.

Single-head pumps

- 32-80/120/150/180/200 F
- 40-80/120/150/180/200/240 F
- 50-60/80/120/150/180/200/240 F
- 65-60/80/120/150/180/200 F

Twin-head pumps

- 32-80/120/150/180/200 F
- 40-80/120/150/180/200/240 F
- 50-60/80/120/150/180/200/240 F
- 65-60/80/120/150/180/200 F

Related information

[Supply flow limit](#)

[Orientations](#)

[13. Product numbers](#)

Performance curves

The following figures show the flow characteristics and performance ranges of the MIXIT variants and applicable pumps, which can be used as guidance for sizing and selecting your MIXIT system.

Settable flow range

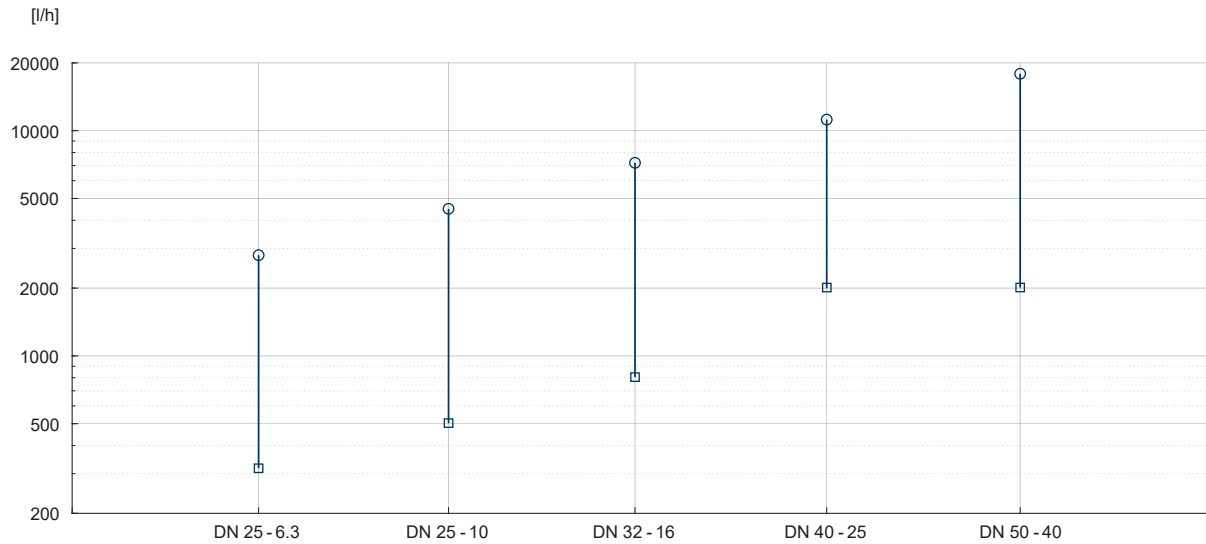

TM071488

Settable flow range for MIXIT operating as a pressure independent, balancing, two-way valve at $\Delta p_{v100} = 20 \text{ kPa}$

Axis	Value
Y	Primary flow, Q [l, h]
X	MIXIT variant

The graph shows the settable flow range for MIXIT operating as a pressure independent, balancing, two-way valve.

Maximum flow is given for a $\Delta p_{v100} = 20 \text{ kPa}$.

Two-way valve

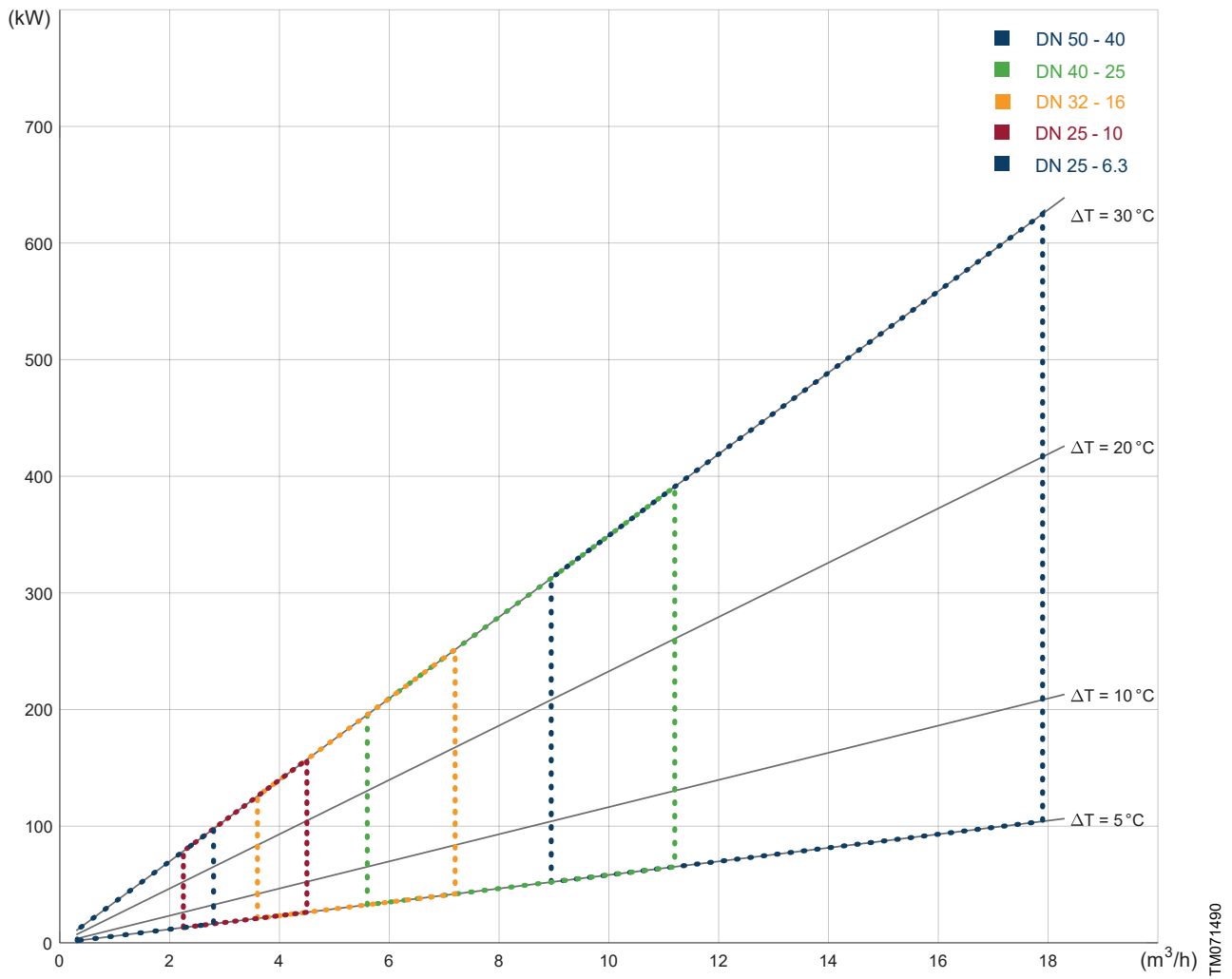

Performance range for two-way MIXIT valve at $\Delta p_{v100} = 20 \text{ kPa}$

Axis	Value
Y	Heating/cooling load, Φ [kW]
X	Secondary flow, Q_s [m³/h]

The figure shows the relationship between flow and heating/cooling load at various values of ΔT . The stippled, coloured areas indicate the range of each available valve size.

Three-way valve

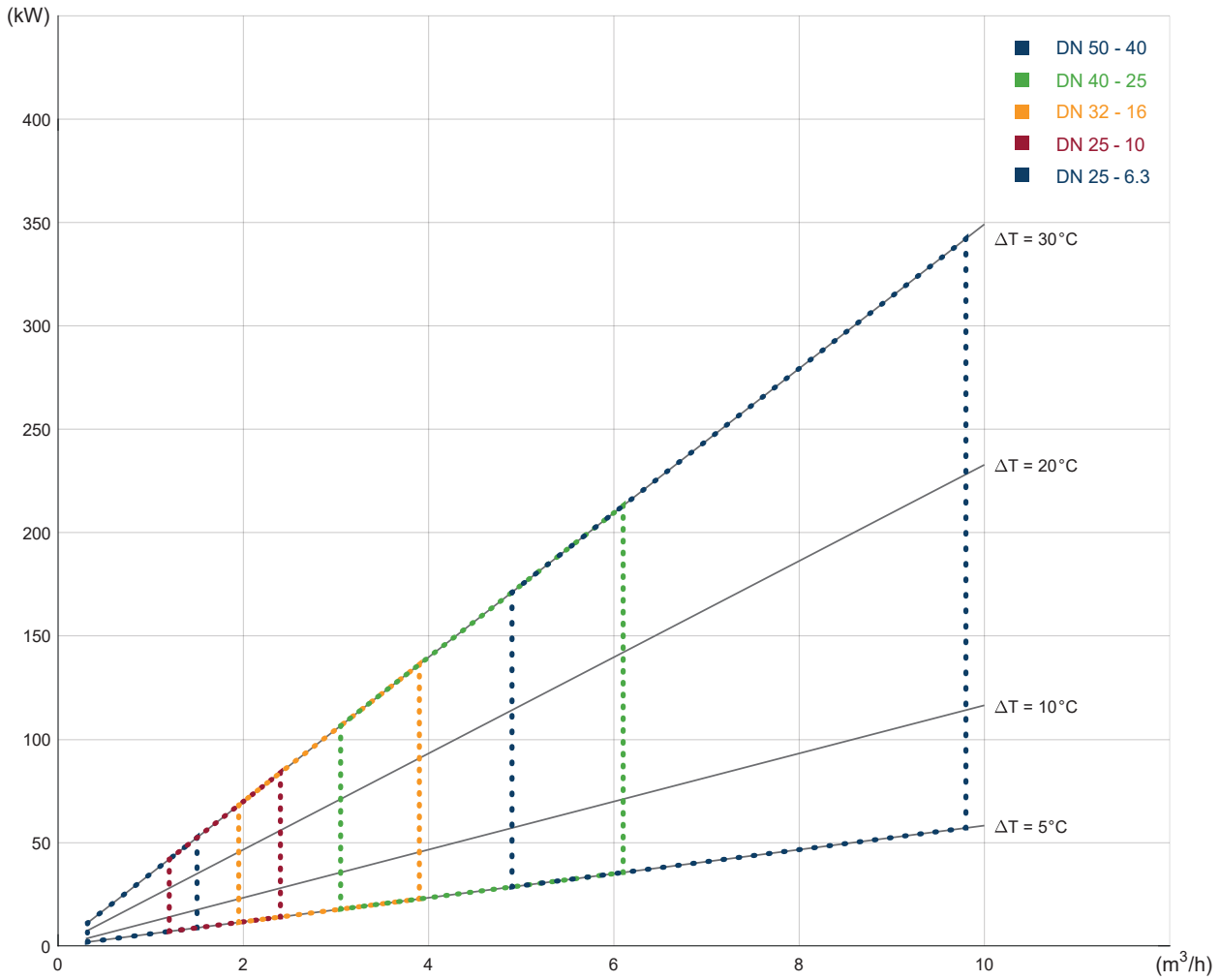

TM071489

Performance range for three-way MIXIT valve at $\Delta p_{V100} = 6 \text{ kPa}$

Axis	Value
Y	Heating/cooling load, Φ [kW]
X	Secondary flow, Q_s [m³/h]

The figure shows the relationship between flow and heat load at various values of ΔT . The stippled, coloured areas indicate the range of each available valve size.

MAGNA3 model D performance range

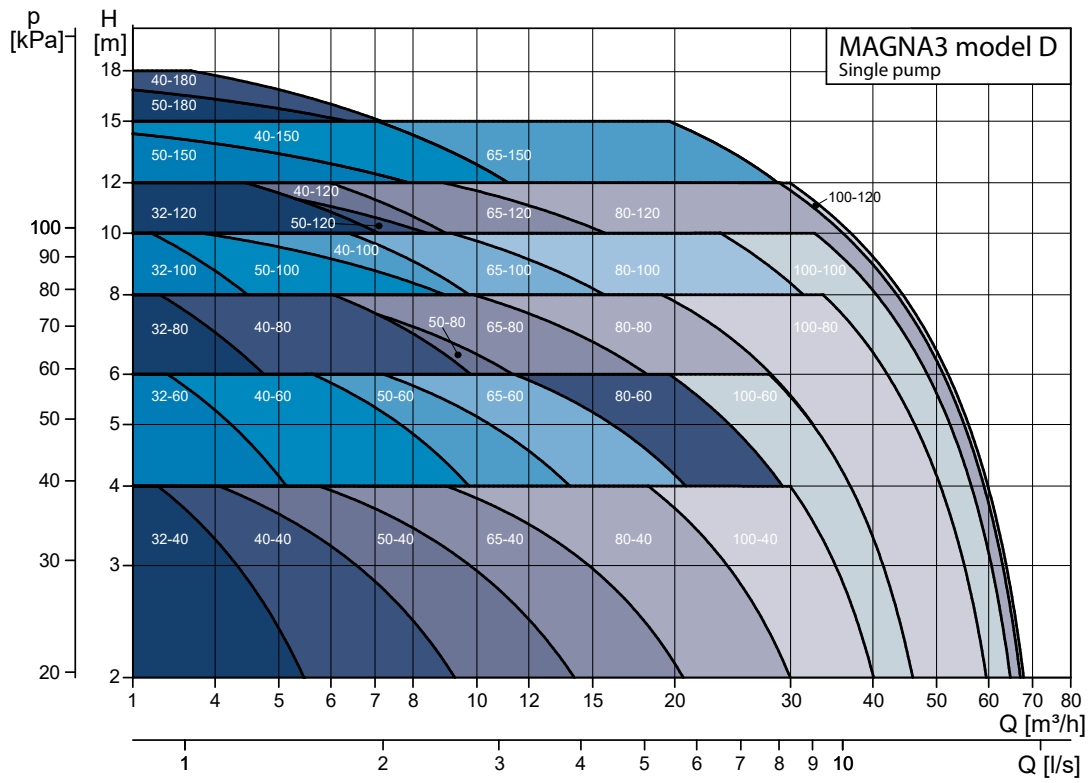

TM053937

MAGNA3 model D single-head operation

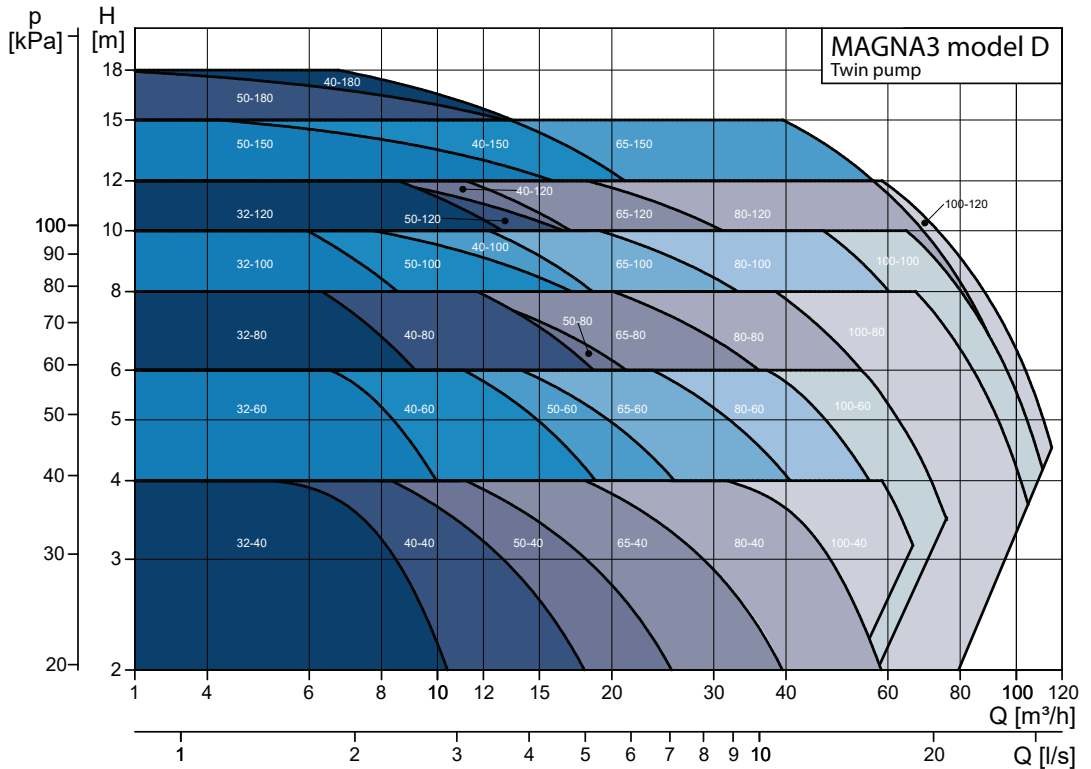

TM053938

MAGNA3 model D twin-head operation

TPE3 D, Single & Twin-head performance range

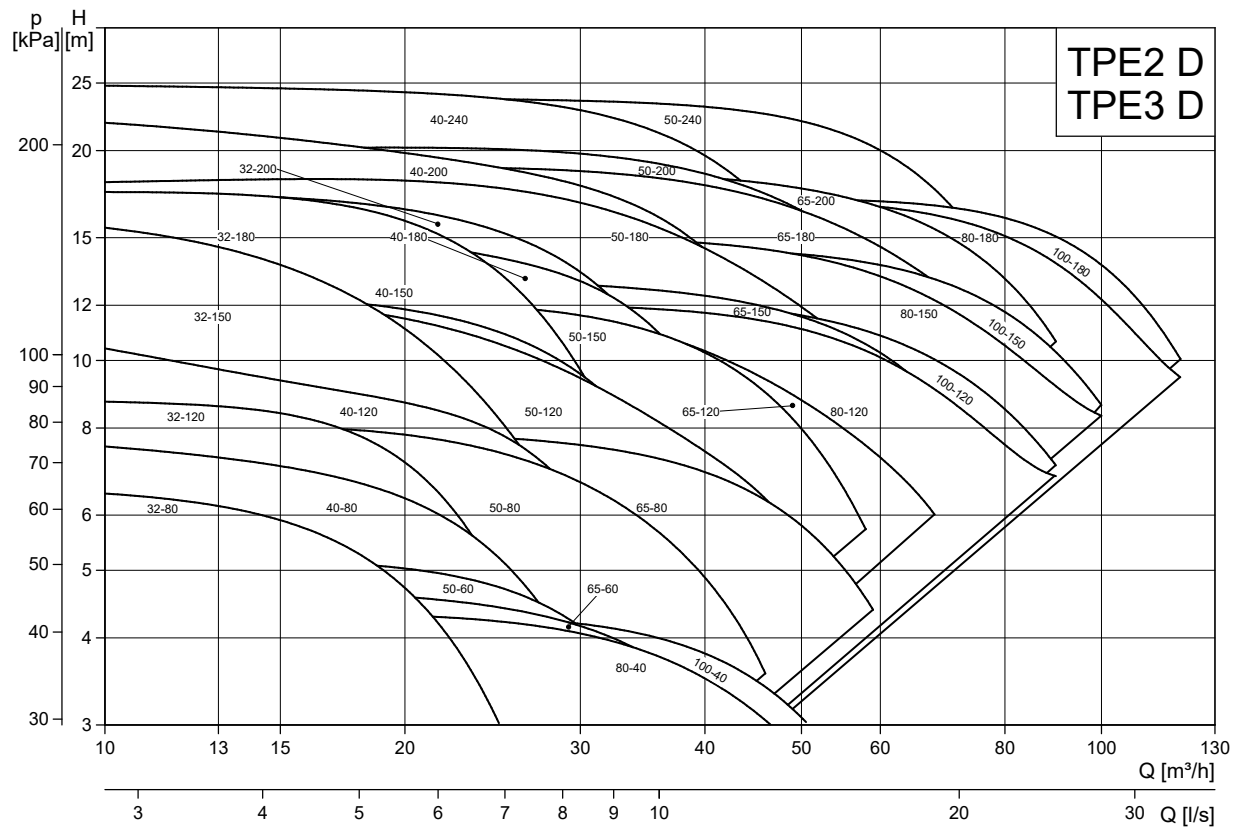

TM058198

TPE3 D, Single & Twin-head operation

3. Guide to selection and sizing

In order to select the optimal valve and pump size, you need to determine the required valve capacity and flow rate for your system.

Selecting the correct pump size

When you have sized the valve, you can select the appropriate pump size based on the desired secondary flow and the head required to overcome secondary side head losses.

MAGNA3/TPE3 pumps applicable for MIXIT can be found in [2. Performance range](#).

Valve selection using performance range curves

MIXIT performance range curves offer a simple selection tool, provided that the pressure differential across the fully open valve in your application matches one of these performance range curves:

Two-way valve with pressure differential $\Delta p_{v100} = 20$ [kPa]

Three-way valve with pressure differential $\Delta p_{v100} = 6$ [kPa]

- Determine two out of three of these parameters:
 - heating/cooling load Φ_s [kW]
 - secondary flow Q_s [m³/h].
 - secondary temperature difference ΔT_s .

If you need to calculate some of the parameters above, use the step-by-step guide. See [3.4 Step-by-step valve sizing guide](#).

- You can go to the relevant performance range curve and select the MIXIT variant that matches your application. See [2.1 Performance curves](#).

Valve sizing based on calculations

The most accurate way to size the valve is to calculate the required valve capacity for your system design flow and match it with the equivalent K_{Vs} from our performance range.

K_v

K_v represents the valve capacity measured as the flow of water in m³/h at a pressure differential of 1 bar across the valve, with the valve open at any position.

K_{Vs}

K_{Vs} is the maximum K_v value measured when the valve is fully open (100%).

For MIXIT, K_{Vs} is measured from port A to AB.

- Use the step-by-step guide below to determine the required valve capacity K_v for your system design. See [3.4 Step-by-step valve sizing guide](#).
- Go to the performance range table and select a valve within the K_{Vs} value range that matches the calculated K_v value. See [2. Performance range](#).

Sizing tool for MIXIT

Use the following links for sizing the MIXIT product.

<https://www.grundfos.com/campaign/mixit-sizing.html>

Step-by-step valve sizing guide

The table below shows examples of applications and parameters used for calculating the correct valve size.

	Example 1 Injection circuit with a two-way valve	Example 2 Mixing circuit with a three-way valve
<p>Primary side:</p> <p>Φ_p: Load [kW]</p> <p>Q_p: Primary flow [m³/h]</p> <p>T_p: Supply temperature [°C]</p> <p>T_r: Return temperature [°C]</p> <p>Secondary side:</p> <p>Φ_s: Load [kW]</p> <p>Q_s: Secondary flow [m³/h]</p> <p>T_s: Forward temperature [°C]</p> <p>T_r: Return temperature [°C]</p> <p>Δp_v: Pressure differential across the valve [kPa]</p>		
<p>1. Known parameters</p> <p>If the load (thermal output power) of your building is unknown, you can estimate the load by multiplying the building class [W/m²] and the area of the building [m²].</p> <p>When the ratio between the primary and secondary ΔT is larger than 6, we recommend that you use an external bypass.</p> <p>Note that the parameters in the examples are not selected on the basis of the circuit type and that they are interchangeable.</p>	<p>$\Phi_s = 200$ [kW]</p> <p>$T_p = 70$ [°C]</p> <p>$T_s = 40$ [°C]</p> <p>$T_r = 30$ [°C]</p>	<p>$Q_s = 3.5$ [m³/h]</p> <p>$T_p = 70$ [°C]</p> <p>$T_s = 60$ [°C]</p> <p>$T_r = 40$ [°C]</p>
<p>2. Calculate the required secondary flow</p> <p>$Q_s = 0.86 \frac{\Phi}{\Delta T_s}$</p> <p>The constant 0.86 is derived from the density and heat capacity of water and the correlation between seconds and hours.</p>	<p>$Q_s = 0.86 \frac{200}{(40 - 30)}$ $Q_s = 17.2$ [m³/h]</p>	<p>$\Phi_s = \frac{3.5(60 - 40)}{0.86}$ $\Phi_s = 81$ [kW]</p>
<p>3. Calculate the primary flow</p> <p>$Q_p = Q_s \frac{\Delta T_s}{\Delta T_p}$</p>	<p>$Q_p = 17.2 \frac{(40 - 30)}{(70 - 30)}$</p> <p>$Q_p = 4.3$ [m³/h]</p>	<p>$Q_p = 3.5 \frac{(60 - 40)}{(70 - 40)}$</p> <p>$Q_p = 2.3$ [m³/h]</p>
<p>4. Choose sizing method</p>		
<p>4A. Calculating K_v</p>	<p>Follow the steps below to calculate the required valve capacity K_v.</p>	<p>Follow the steps below to calculate the required valve capacity K_v.</p>
<p>4A.1 Determine the pressure differential</p> <p>Δp_{v100} = required pressure drop across the fully open valve.</p> <p>Typical design pressure drop:</p> <ul style="list-style-type: none"> Two-way valve in pressurised distribution system: $\Delta p_{v100} = 10$ kPa (typical value) Three-way valve in pressure-less system: $\Delta p_{v100} = 6-8$ kPa. (Sized by K_{vs} value) 	<p>Example:</p> <p>$\Delta p_{v100} = 10$ [kPa]</p>	<p>Example:</p> <p>$\Delta p_{v100} = 6$ [kPa]</p>

	Example 1 Injection circuit with a two-way valve	Example 2 Mixing circuit with a three-way valve
<p>4A.2 Calculate the required valve capacity K_v in m^3/h</p> $K_v = \frac{Q_p}{\sqrt{\frac{\Delta p_{v100}}{100}}}$	$K_v = \frac{4.3}{\sqrt{\frac{10}{100}}}$ $K_v = 13.6 [m^3/h]$	$K_v = \frac{2.3}{\sqrt{\frac{6}{100}}}$ $K_v = 9.4 [m^3/h]$
<p>4A.3 Select valve</p> <p>Go to the performance range table and select a valve within a K_{vs} range that matches your calculated K_v value. Select the closest match, which provides the most economical valve that ensures sufficient valve authority.</p> <p>Find the table in 2. Performance range.</p> <p>When MIXIT is installed, you can control the valve position via Grundfos GO Remote to match the required pressure differential K_v for your system design.</p>	<p>MIXIT DN 32-16: K_{vs} value: 1.6 - 16 [m^3/h] Flow range: 0.8 - 8.8 [m^3/h]</p>	<p>MIXIT DN 25-10: K_{vs} value: 1 - 10 [m^3/h] Flow range: 0.5 - 5.5 [m^3/h]</p>
<p>4B. Settable flow range graph</p> <p>Use the settable flow range graph to size and select your MIXIT variant. Find the graph in 2.1 Performance curves.</p> <p>Typical design pressure drop:</p> <ul style="list-style-type: none"> Pressure independent valves: $\Delta p_{v100} = 15-25$ kPa. (Sized by flow). Please note that MIXIT does not require any minimum pressure differential to function as a pressure independent valve. 	<p>Valid for pressure independent two-way valves with balancing and with a pressure differential Δp_{v100} equal to 20 [kPa].</p> <p>Example: Flow $Q_p = 4.3 [m^3/h] = 4300 [l/h]$ Selection via settable flow range graph: MIXIT DN 25-10 Flow range: up to 4500 [l/h]</p> <p>When MIXIT is installed, you can control the valve position via Grundfos GO Remote and set the flow limit to match the required pressure differential K_v for your system design.</p>	<p>Not applicable for three-way valves.</p>

4. System applications

Mixing loops are used whenever there is a need for controlling the flow temperature. The basic principle is to mix the primary water with the return water to obtain the required mixed flow temperature. When it comes to MIXIT, it can be used in HVAC systems with the following types of consumers:

- Radiator heating
- Underfloor heating
- Air handling unit
- General cooling units
- Combined units (Cooling & heating)

When applied to a primary distribution circuit, the heating system acts as a secondary circuit. In a temperature-controlled circuit, different types of mixing circuits are used. MIXIT can be applied to the following three circuit types working either as a two- or three-way valve:

Pressurised distribution circuits

- Injection circuit with a two-way valve
- Injection circuit with a three-way valve

Non-pressurised distribution circuit

- Mixing circuit with a three-way valve.

System integration

Thanks to the integrated fieldbus, MIXIT can be incorporated into any building management system (BMS) using the RS485 terminal or ethernet port.

RS485

- BACnet MS/TP protocol
- Modbus RTU protocol.

Ethernet

- BACnet IP protocol
- Modbus TCP protocol
- Grundfos BuildingConnect.

Related information

[Fieldbus integration](#)

[Setting up the product using Grundfos GO Remote](#)

Distribution circuits

Injection circuit with a two-way valve - heating system

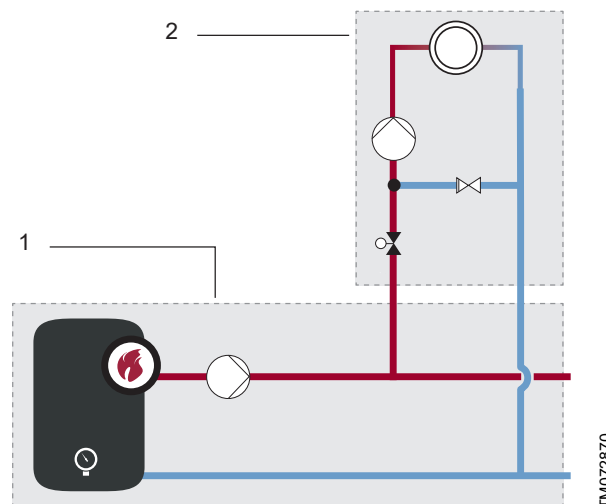

TM072870

Pos.	Description
1	Primary system
2	Secondary system

This type of mixing circuit is the most common one in all new installations.

The injection circuit operates with a variable flow on the primary side (1) and a constant flow on the secondary side (2).

Hot water is injected through a two-way valve into the secondary system (2) by opening the valve. On the secondary side (2), cold water from the return pipe is mixed in through a bypass. The more water injected from the primary side (1), the less water is flowing through the bypass, resulting in a constant flow with a variable temperature at the load.

Because the bypass acts as a hydraulic short circuit, the pump in the secondary system (2) is not able to pump the water into the primary circuit. Therefore, this type of circuit is always pressurised in the primary system (1).

Injection circuit with a two-way valve - Cooling system

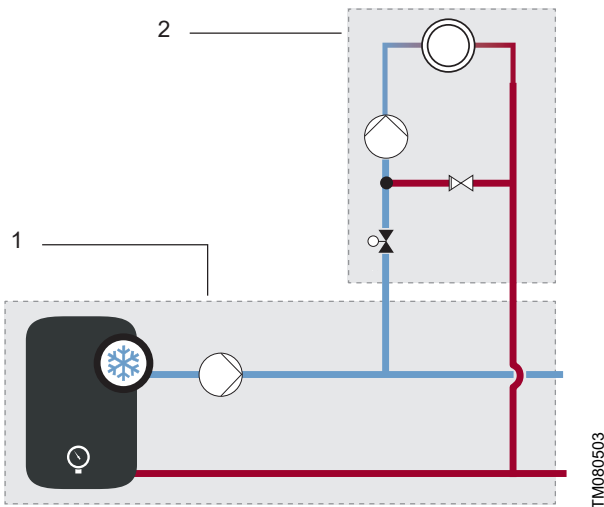

Pos.	Description
1	Primary system
2	Secondary system

This type of mixing circuit is the most common one in all new installations.

The injection circuit operates with a variable flow on the primary side (1) and a constant flow on the secondary side (2).

Cold water is injected through a two-way valve into the secondary system (2) by opening the valve. On the secondary side (2), Warm water from the return pipe is mixed in through a bypass. The more water injected from the primary side (1), the less water is flowing through the bypass, resulting in a constant flow with a variable temperature at the load.

Because the bypass acts as a hydraulic short circuit, the pump in the secondary system (2) is not able to pump the water into the primary circuit. Therefore, this type of circuit is always pressurised in the primary system (1).

Injection circuit with a three-way valve - heating system

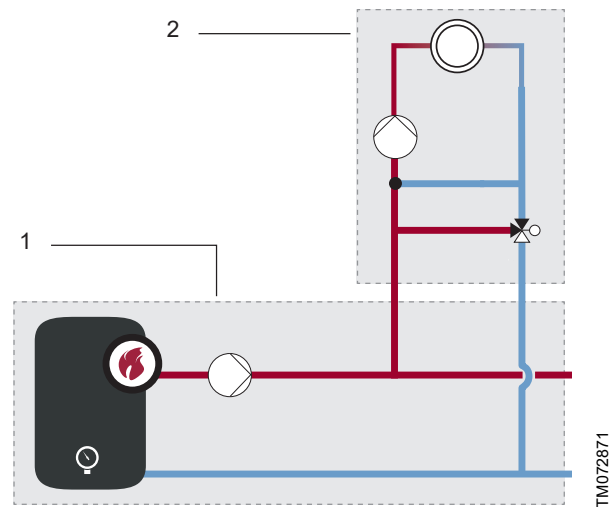

Pos.	Description
1	Primary system
2	Secondary system

This type of circuit is advantageous when a fast response time is required and is often found in systems with long distances between heat generation and load. Because the flow and temperature in the primary system (1) are constant, the temperature in the secondary system (2) will increase instantly when water from the primary circuit is injected. The circuit is rarely used, though, as part of the primary flow is recirculated, and it is not applicable for district heating and condensing boiler because of the potential high temperatures in the system.

Injection circuit with a three-way valve - cooling system

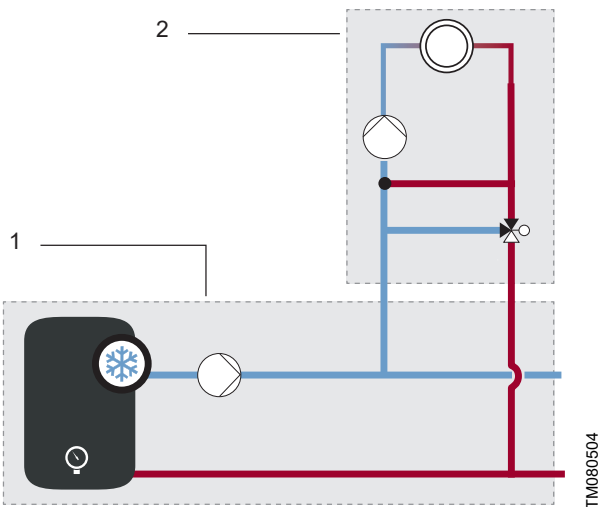

TM080504

Pos.	Description
1	Primary system
2	Secondary system

This type of circuit is advantageous when a fast response time is required. Because the flow and temperature in the primary system (1) are constant, the temperature in the secondary system (2) will decrease instantly when water from the primary circuit is injected.

Mixing circuit with a three-way valve - heating system

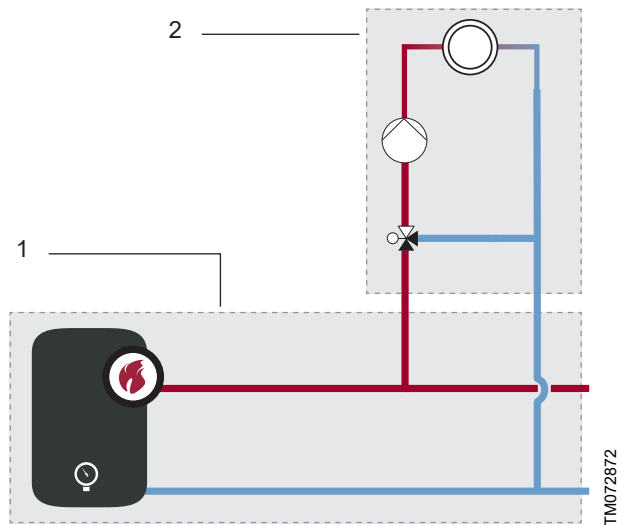

TM072872

Pos.	Description
1	Primary system
2	Secondary system

The mixing circuit with a three-way valve is typically used in systems where the heat source allows a variable flow through it. Under these conditions, it is not necessary to have a primary pump. For this reason, this mixing circuit is not valid in applications where the boiler is far away from the valve.

The mixing circuit operates with a variable flow on the primary side (1) and a constant flow on the secondary side (2).

In this circuit, hot water is led through a three-way valve into the secondary system (2). Part of the secondary flow is recirculated through the valve. The two flows are mixed together at the mixing point inside the valve.

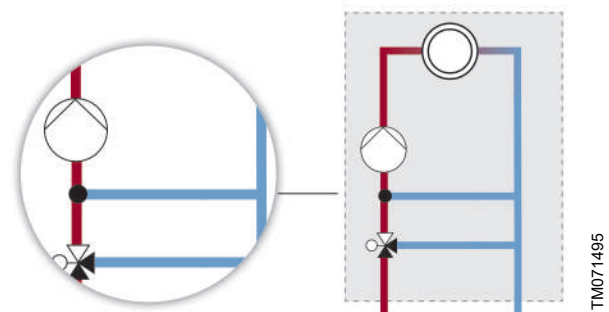

TM071495

Fixed bypass in a mixing circuit with a three-way valve

When the primary flow temperature is significantly higher than the maximum secondary flow temperature, we recommend that you use the three-way mixing circuit with a fixed bypass. This is because the bypass ensures injection of return water even in the rare event of power failure or a stuck valve.

Mixing circuit with a three-way valve - cooling system

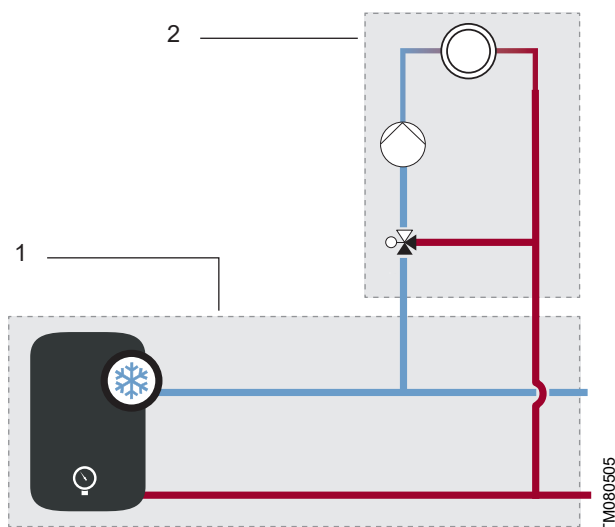

Pos.	Description
1	Primary system
2	Secondary system

The mixing circuit with a three-way valve is typically used in systems where the cooling source allows a variable flow through it. Under these conditions, it is not necessary to have a primary pump. For this reason, this mixing circuit is not valid in applications where the cooling unit is far away from the valve.

The mixing circuit operates with a variable flow on the primary side (1) and a constant flow on the secondary side (2).

In this circuit, cold water is led through a three-way valve into the secondary system (2). Part of the secondary flow is recirculated through the valve. The two flows are mixed together at the mixing point inside the valve.

Combined heating and cooling system (mixing circuit, injection circuit, two-way valve and three-way valve)

The combined system (heating & cooling) uses both:

- injection circuit with two-way & three-way valve.
- mixing circuit with three-way valve

Combined systems are systems where the primary system can supply both hot and cold water. MIXIT can control the flow temperature for both heating and cooling in the secondary system. Changing the temperature controller between heating and cooling is done using external input or via fieldbus.

MIXIT in a radiator heating system

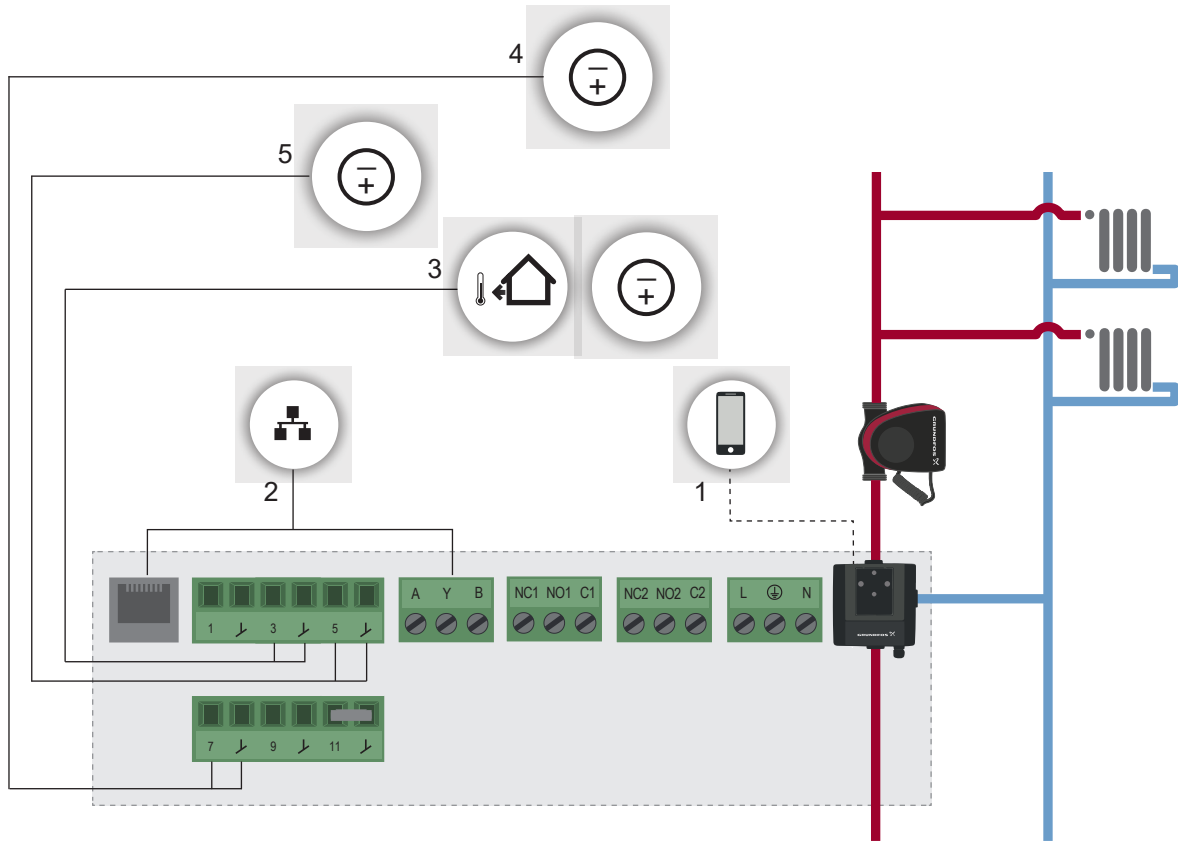

TM072873

Example of external connections in a radiator heating system

Pos.	Description
1	Bluetooth connection to smartphone via Grundfos GO Remote
2	Integration into BMS system
3	Outdoor temperature sensor (Pt1000) or External setpoint
4	Supply source set point
5	Daisy chain

In radiator heating systems, MIXIT will control the flow temperature supplied to the radiators. It can be used in both one- and two-pipe radiator installations. We recommend that you use thermostats on the individual radiators to set the desired room temperatures.

In the installation example above, MIXIT is configured with an outdoor temperature sensor, which is perfect for utilising the following features:

- weather curve
- warm-weather shutdown.

Data

MIXIT receives data on the mixed flow temperature from the pump's temperature sensor, while MIXIT itself measures:

- flow and temperature of the A port
- temperature of the B port.

These data can be used for the following features:

- temperature control
- pressure independence
- return temperature limit
- thermal power limit
- heat monitor.

Related information

[6. Functions overview](#)

[Terminal connections overview](#)

Radiator heating, terminal connections

In a radiator heating system, the terminals can be used for the following:

Ether net	RJ45		Communication to Grundfos BuildingConnect, Modbus TCP and BACnet IP.
	1	+24 Volt	24 VDC supply for an active sensor. The 0-10 V temperature sensor can be used when several MIXIT units in a system share the same temperature sensor.
	↓	GND	
I/O	3	CI01	Outdoor temperature sensor (Pt1000 or 0-10 V) or external setpoint input.
	↓	GND	
	5	CI02	Daisy chain. It is used to connect two or more MIXIT to support supply source setpoint.
	↓	GND	
	7	CI03	Supply source setpoint voltage. It is used so MIXIT can control the supply source output temperature and reduce pipe heat loss.
	↓	GND	
I/O	9	DI4	External setpoint reduce. When the digital input is activated, MIXIT reduces the setpoint by 5 °C.
	↓	GND	
	11	DI5	External start/stop of both MIXIT and pump.
	↓	GND	

RS485	A	GENIbus, BACnet MS/TP or Modbus RTU	Signal input and output from the BMS system.
	Y		
	B		
Relay 1	NC1		Fault signal. A NC/NO output signal, which will be active in case of fault.
	NO1		
	C1		
Relay 2	NC2		Run signal. A NC/NO output signal, which is active when MIXIT operates without alarms.
	NO2		
	C2		
AC suppl y	L	Mains supply	Power supply connection, 230 V ± 10 %
	Earth		
	N		

Configuring the I/O terminals according to the terminal connections table

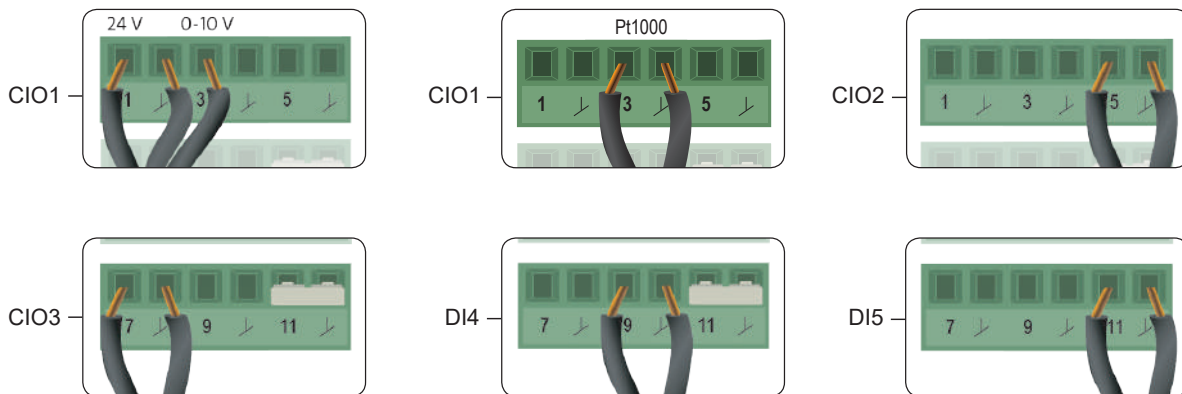

TM074677

MIXIT in a underfloor heating system

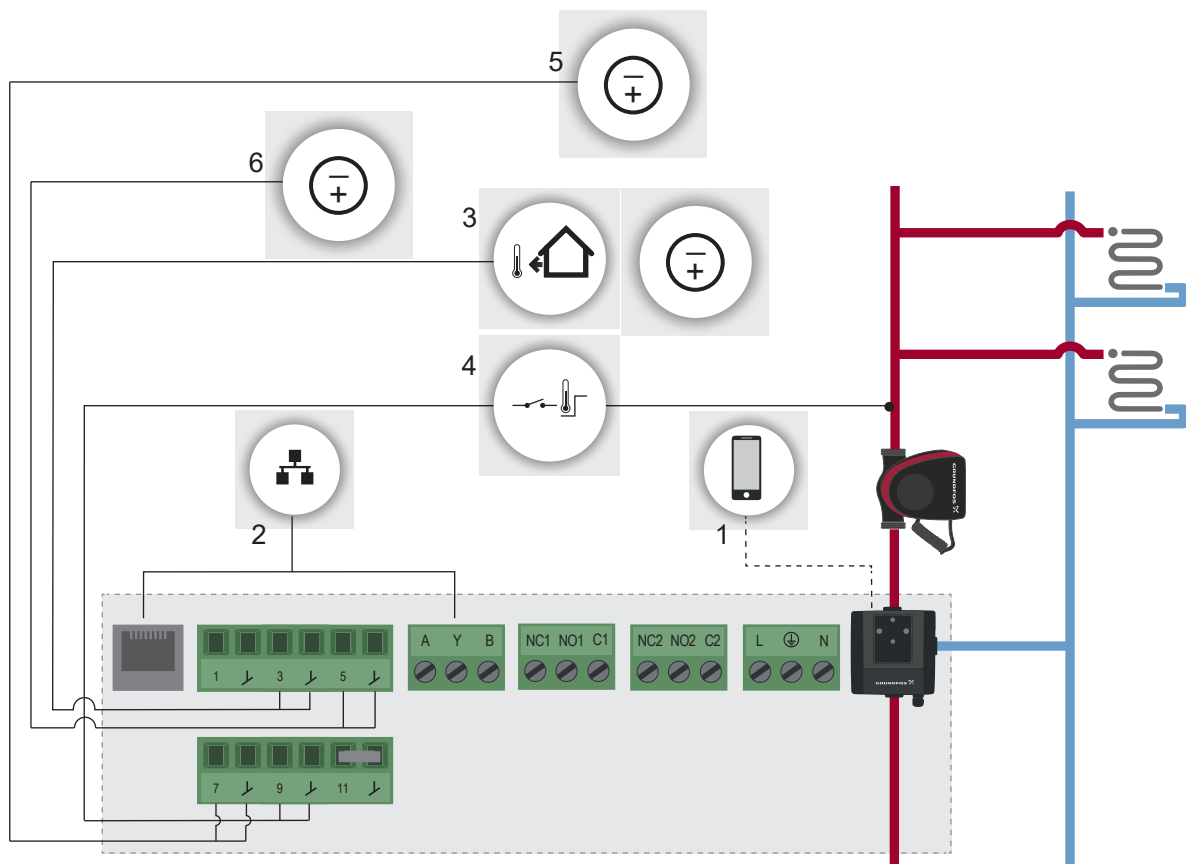

TM072874

Example of external connections in a underfloor heating system

Pos.	Description
1	Bluetooth connection to smartphone via Grundfos GO Remote
2	Integration into BMS system
3	Outdoor temperature sensor (Pt1000) or External setpoint
4	Temperature protection switch (extra thermal protection)
5	Supply source setpoint
6	Daisy chain

In underfloor heating systems, MIXIT will control the flow temperature supplied to the connected underfloor heating zones.

In the installation example above, MIXIT is configured with the following:

- An outdoor temperature sensor, perfect for utilising the following features:
 - weather curve
 - warm-weather shutdown.
- A bimetallic temperature protection switch providing thermal protection. Once a defined maximum temperature is reached, the temperature switch activates the input terminal of the MIXIT unit causing the valve to close. The switch acts as extra protection as MIXIT already controls the mixed flow temperature and has a built-in floor overheat protection function. See [6.2 Underfloor overheat protection](#).

Data

MIXIT receives data on the mixed flow temperature from the pump's temperature sensor, while MIXIT itself measures:

- flow and temperature of the A port
- temperature of the B port.

These data can be used for the following features:

- temperature control
- pressure independence
- return temperature limit
- thermal power limit
- heat monitor.

Related information

[6. Functions overview](#)

[Terminal connections overview](#)

Underfloor heating, terminal connections

In an underfloor heating system the terminals can be used for the following:

Ether net	RJ45		Communication to Grundfos BuildingConnect, Modbus TCP and BACnet IP.
I/O	1	+24 Volt	24 VDC supply for an active sensor. The 0-10 V temperature sensor can be used when several MIXIT units in a system share the same temperature sensor.
	↙	GND	
I/O	3	CI01	Outdoor temperature sensor (Pt1000 or 0-10 V) or external setpoint input.
	↙	GND	
I/O	5	CI02	Daisy chain. It is used to connect two or more MIXIT to support supply source setpoint.
	↙	GND	
I/O	7	CI03	Supply source setpoint voltage. It is used so MIXIT can control the supply source output temperature and reduce pipe heat loss.
	↙	GND	
I/O	9	DI4	External overheat indicator.
	↙	GND	
I/O	11	DI5	External start/stop of both MIXIT and pump.
	↙	GND	

RS485	A	GENIbus, BACnet MS/TP or Modbus RTU	Signal input and output from the BMS system.
	Y		
	B		
Relay 1	NC1		Fault signal. A NC/NO output signal, which will be active in case of fault.
	NO1		
	C1		
Relay 2	NC2		Run signal. A NC/NO output signal, which is active when MIXIT operates without alarms.
	NO2		
	C2		
AC suppl y	L	Mains supply	Power supply connection, 230 V ± 10 %
	Earth		
	N		

Configuring the I/O terminals according to the terminal connections table

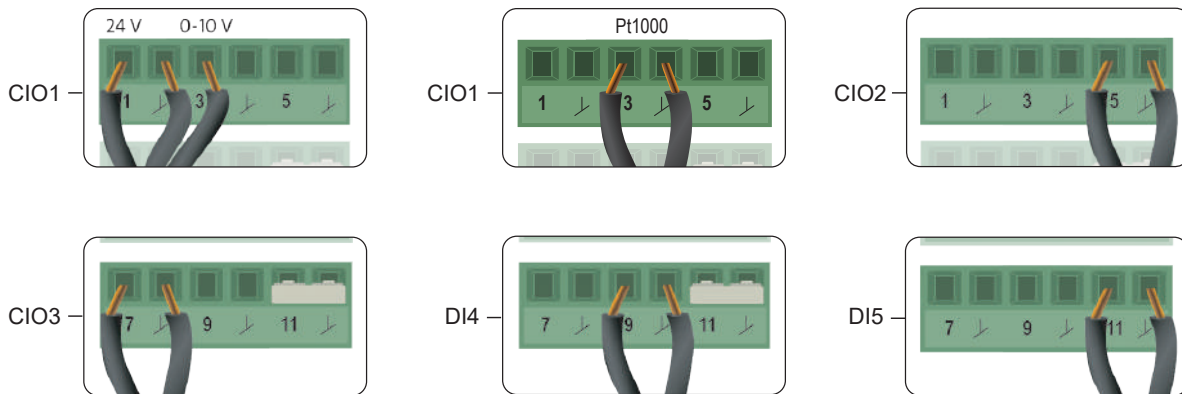

TM074676

MIXIT in an air handling unit system

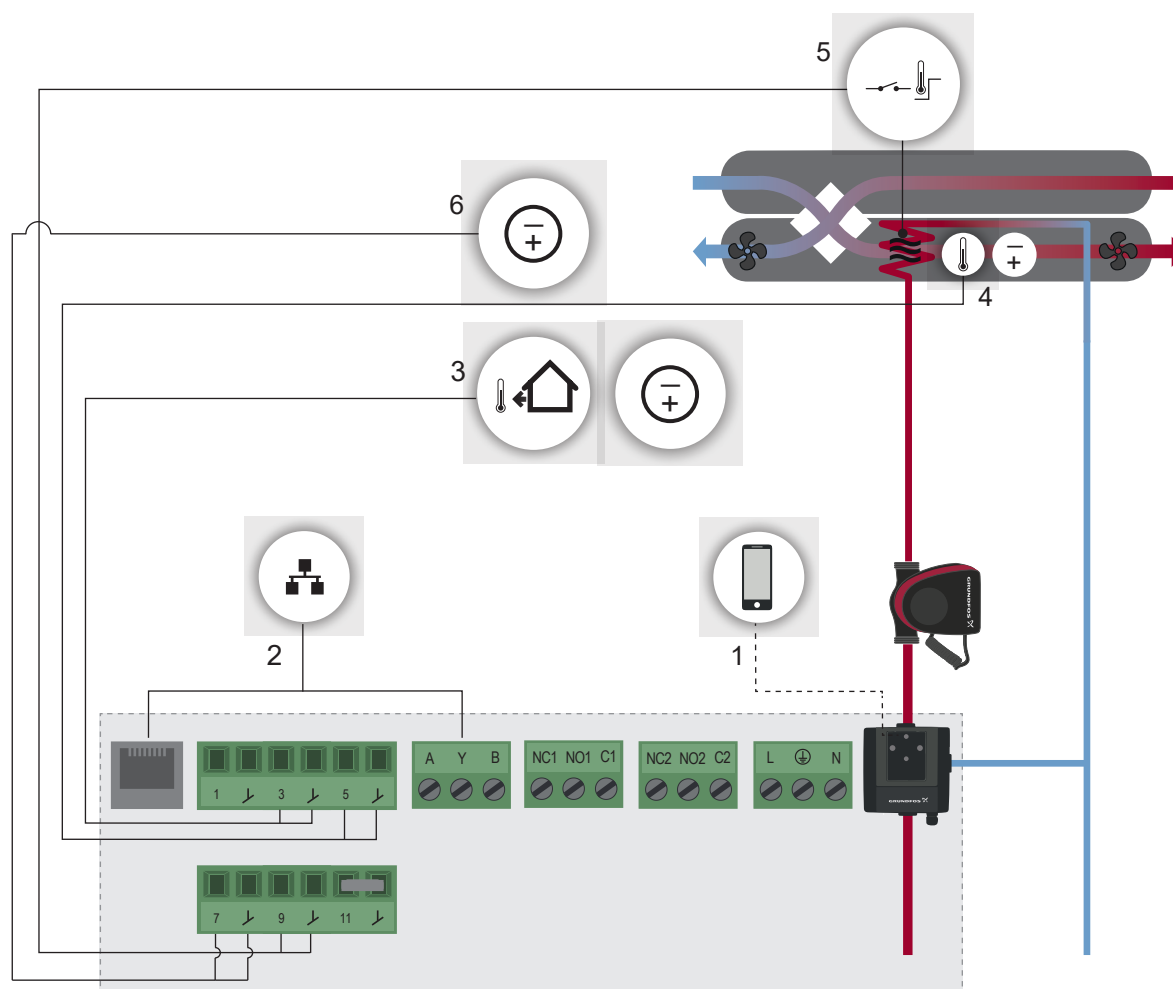

TM072875

Example of external connections in an air handling unit

Pos.	Description
1	Bluetooth connection
2	System integration
3	Outdoor temperature sensor (Pt1000) or External setpoint
4	Air temperature sensor or Daisy chain
5	Antifreeze sensor (extra protection against freezing)
6	Supply source setpoint

In air handling unit systems, MIXIT will control the flow temperature supplied to the air coil placed within the air handling unit. The flow temperature will be determined by the setpoint of the air temperature measured in the outlet temperature of the air handling unit.

In the installation example above, MIXIT is configured with:

- An outdoor temperature sensor, perfect for utilising the following features:
 - weather curve
 - warm-weather shutdown.

- An antifreeze sensor for the system to avoid ice building up in the air handling unit and frost damage. The sensor acts as extra protection, as MIXIT offers several antifreeze functions to protect the system:
 - A purge function which preheats the coil before activating the enable signal in relay 2. The signal can be used to open the dampers and let in air. Furthermore, an internal frost protection function can be set. Both functions are available when setting up MIXIT in Grundfos GO Remote. See [6.3 Heating coil preheat and frost protection](#).
 - MIXIT has a digital input, which can be connected to an external bimetalic temperature switch.
- An air temperature sensor placed in the outlet of the unit to ensure correct air temperature.

Data

MIXIT receives data on the mixed flow temperature from the pump's temperature sensor, while MIXIT itself measures:

- flow and temperature of the A port
- temperature of the B port.

These data can be used for the following features:

- temperature control
- pressure independence
- return temperature limit
- thermal power limit
- heat monitor.

Related information

[6. Functions overview](#)

[Terminal connections overview](#)

Air handling unit, terminal connections

In an air handling unit system, the terminals can be used for the following:

Ether net	RJ45		Communication to Grundfos BuildingConnect, Modbus TCP and BACnet IP.
I/O	1	+24 Volt	24 VDC supply for an active sensor. The 0-10 V temperature sensor can be used when several MIXIT units in a system share the same temperature sensor.
	↓	GND	
	3	CI01	Outdoor temperature sensor (Pt1000 or 0-10 V) or external setpoint input.
	↓	GND	
I/O	5	CI02	Air temperature sensor or Daisy chain
	↓	GND	
	7	CI03	Supply source setpoint voltage. It is used so MIXIT can control the supply source output temperature and reduce pipe heat loss.
	↓	GND	
I/O	9	DI4	External frost indicator.
	↓	GND	
	11	DI5	External start/stop of both MIXIT and pump.
	↓	GND	

RS485	A	GENIbus, BACnet MS/TP or Modbus RTU	Signal input and output from the BMS system.
	Y		
	B		
Relay 1	NC1		Fault signal. A NC/NO output signal, which will be active in case of fault.
	NO1		
	C1		
Relay 2	NC2		Run signal. A NC/NO output signal, which is active when MIXIT operates without alarms. The signal is inactive when frost protection.
	NO2		
	C2		
AC suppl y	L	Mains supply	Power supply connection, 230 V ± 10 %
	Earth		
	N		

Configuring the I/O terminals according to the terminal connections table

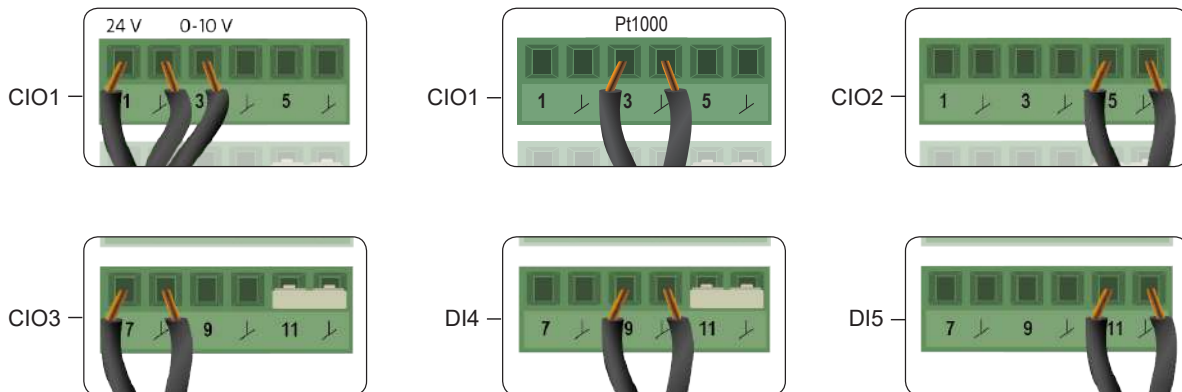

TM074684

MIXIT in a cooling system

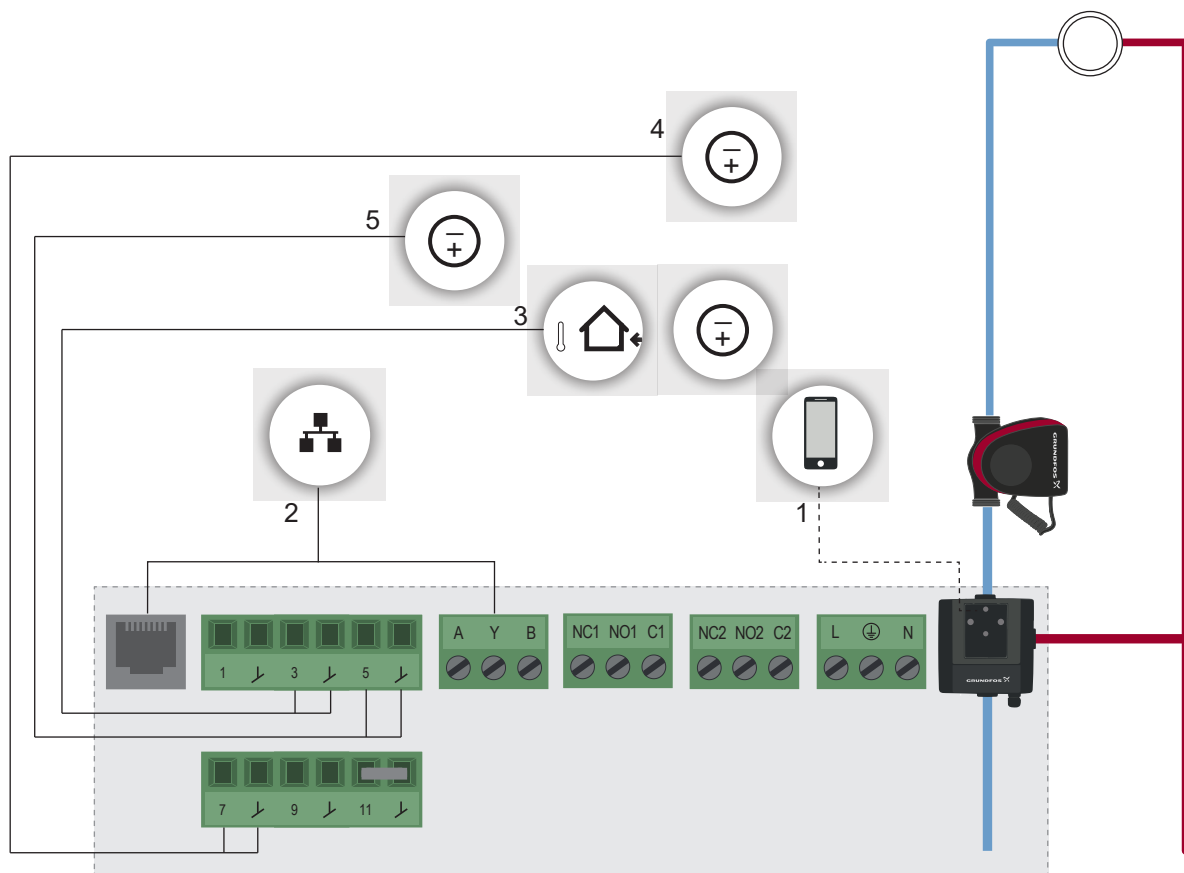

TM080501

Example of cooling system

Pos.	Description
1	Bluetooth connection to smartphone via Grundfos GO Remote
2	Integration into BMS system
3	Outdoor temperature sensor (Pt1000 or 0-10 V) or external setpoint
4	Supply source setpoint
5	Daisy chain

In cooling systems, MIXIT will control the flow temperature supplied to the cooling systems.

Data

MIXIT receives data on the mixed flow temperature from the pump's temperature sensor, while MIXIT itself measures:

- flow and temperature of the A port
- temperature of the B port.

These data can be used for the following features:

- temperature control
- pressure independence
- return temperature limit
- thermal power limit
- energy monitor

Cooling, terminal connections

In the cooling system, the terminals can be used for the following:

Ether net	RJ45		Communication to Grundfos Building Connect, Modbus TCP and BACnet IP.	
I/O	1	+24 Volt	24 VDC supply	
	↘	GND		
	3	CI01	Outdoor temperature sensor (Pt1000 or 0-10 V) or External setpoint input (0-10 V, 0-20 mA, 4-20 mA setup via Grundfos GO)	
	↘	GND		
I/O	5	CI02	Daisy chain. It is used to connect two or more MIXIT to support supply source setpoint.	
	↘	GND		
	I/O	7	CI03	Supply source setpoint voltage. It is used so MIXIT can control the supply source output temperature and reduce pipe energy loss.
		↘	GND	
I/O		9	DI4	
		↘	GND	
	I/O	11	DI5	External start/stop of both MIXIT and pump.
		↘	GND	

RS485	A	GENIbus, BACnet MS/TP or Modbus RTU	Signal input and output from the BMS system.
	Y		
	B		
Relay 1	NC1		Fault signal. A NC/NO output signal, which will be active in case of fault.
	NO1		
	C1		
Relay 2	NC2		Run signal. A NC/NO output signal, which is active when MIXIT operates without alarms. The signal is inactive when frost protection.
	NO2		
	C2		
AC suppl y	L	Mains supply	Power supply connection, 230 V ± 10 %
	Earth		
	N		

Configuring the I/O terminals according to the terminal connections table

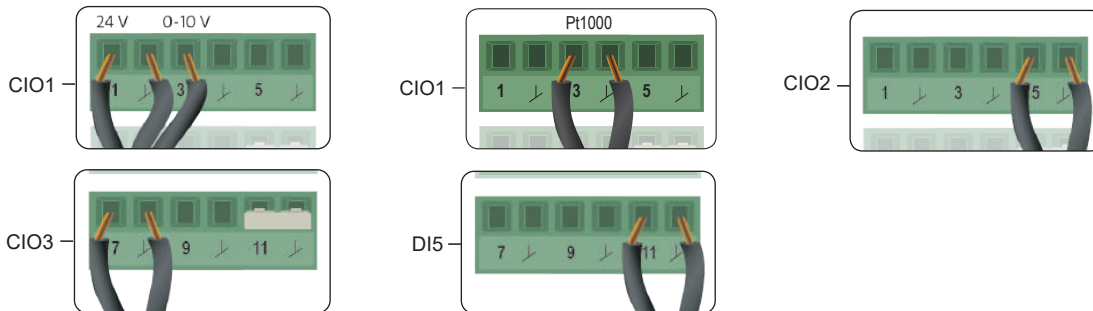

TM081863

MIXIT in a combined system (heating & cooling)

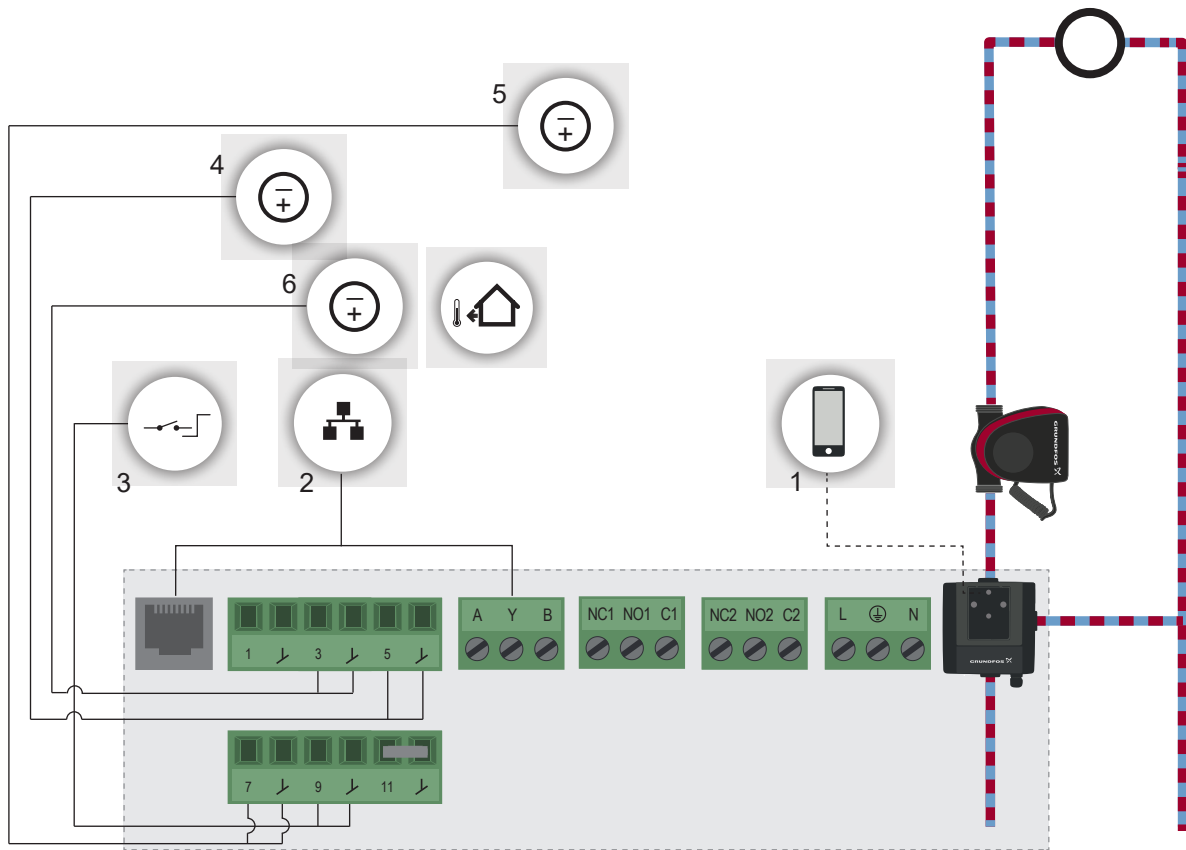

TM080502

Example of combined system (heating & cooling)

Pos.	Description
1	Bluetooth connection to smartphone via Grundfos GO Remote
2	Integration into BMS system
3	DI4 (To switch between heating and cooling mode)
4	Daisy chain
5	Supply source setpoint
6	Outdoor temperature sensor (Pt1000 or 0-10 V) or External setpoint

- thermal power limit
- energy monitor

In combined systems, MIXIT will control the flow temperature supplied to the heating/cooling systems based on which system is selected for use.

In the installation example above, MIXIT is configured with an external switch that changes between heating and cooling mode, which is perfect for utilising the following features:

Data

MIXIT receives data on the mixed flow temperature from the pump's temperature sensor, while MIXIT itself measures:

- flow and temperature of the A port
- temperature of the B port.

These data can be used for the following features:

- temperature control
- pressure independence
- return temperature limit

Combined heating and cooling, terminal connections

In the combined heating and cooling, the terminals can be used for the following:

Ether net	RJ45		Communication to Grundfos BuildingConnect, Modbus TCP and BACnet IP.	
I/O	1	+24 Volt	24 VDC supply	
	↘	GND		
	3	CI01	Outdoor temperature sensor (Pt1000 or 0-10 V) or external setpoint input (0 -10 V, 0 -20 mA, 4 - 20 mA setup via Grundfos GO)	
	↘	GND		
I/O	5	CI02	Daisy chain. It is used to connect two or more MIXIT to support supply source setpoint.	
	↘	GND		
	I/O	7	CI03	Supply source setpoint voltage. It is used so MIXIT can control the supply source output temperature and reduce pipe energy loss.
		↘	GND	
I/O		9	DI4	Switches between heating and cooling. When the digital input is active, MIXIT will be set up for the cooling.
		↘	GND	
	I/O	11	DI5	External start/stop of both MIXIT and pump.
		↘	GND	

RS485	A	GENIbus, BACnet MS/TP or Modbus RTU	Signal input and output from the BMS system.
	Y		
	B		
Relay 1	NC1		Fault signal. A NC/NO output signal, which will be active in case of fault.
	NO1		
	C1		
Relay 2	NC2		Run signal. A NC/NO output signal, which is active when MIXIT operates without alarms. The signal is inactive when frost protection.
	NO2		
	C2		
AC supply y	L	Mains supply	Power supply connection, 230 V ± 10 %
	Earth		
	N		

Configuring the I/O terminals according to the terminal connections table

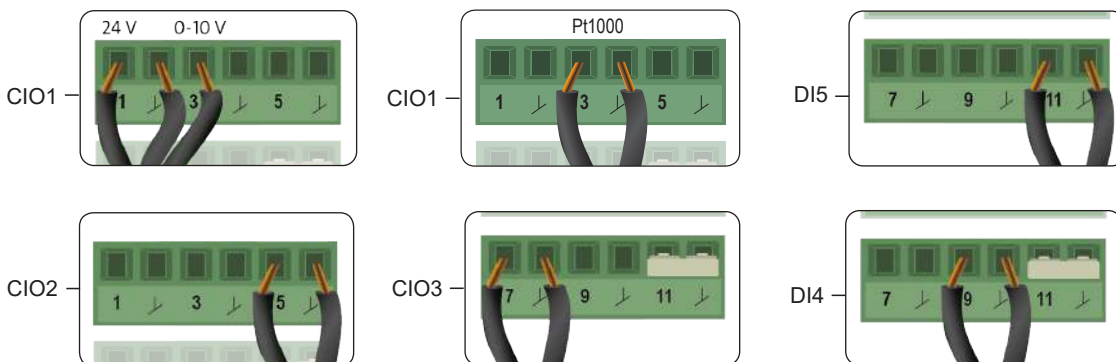

During commissioning, it is possible to change over between heating and cooling control by activating DI4.

5. Components

Threaded Version

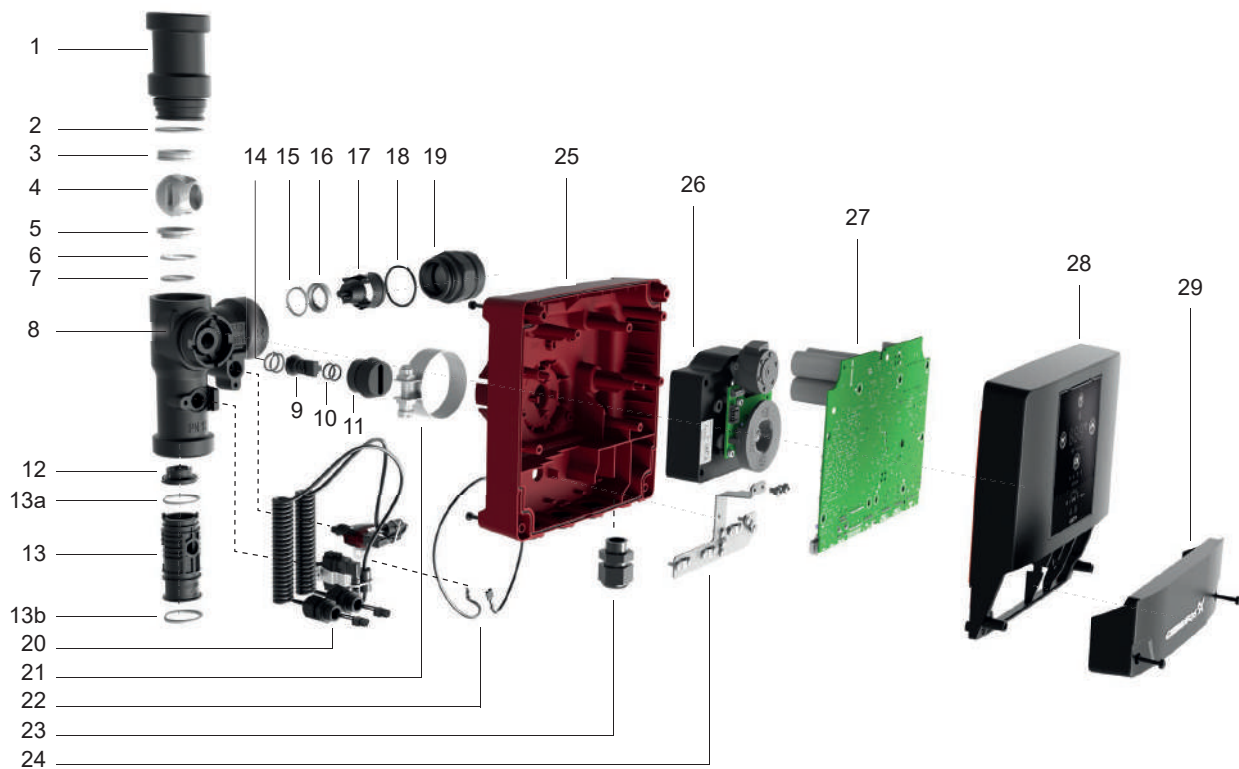

TM071483

Pos.	Description	Material
1	Retainer AB	Cast iron GJS500-7 and CED
2	O-ring	EPDM (EP70)
3	Seat AB	Carbon reinforced PTFE
4	Ball valve	Brass CW641N, Ni and Cr
5	Seat A	Carbon reinforced PTFE
6	Washer	Stainless steel EN1.4301
7	O-ring	EPDM (EP70)
8	Valve body	Cast iron GJS500-7 and CED
9	Stem	Stainless steel
10	O-rings	EPDM (EP70)
11	Coupling	Brass CW614N
12	Flow restriction disc	PPS 40-GF
13	Flow insert	PPS 40-GF
13a	O-ring	EPDM (EP70)
13b	O-ring	EPDM (EP70)
14	Bearings for stem	PTFE

Pos.	Description	Material
15	O-ring	EPDM (EP70)
16	Seat B	Carbon reinforced PTFE
17	Non-return valve	EPDM, Stainless steel, PPO
18	O-ring	EPDM (EP70)
19	Retainer B	Cast iron GJS500-7 and CED
20	Sensors	Wetted materials: Corrosion-resistant coating, EPDM, PPS
21	Clamp	Stainless steel EN1.4301
22	Grounding cable	
23	Cable gland	PA
24	Earth plate	Stainless steel
25	Control box housing	Makrolon 9415 PC 10%GF FR
26	Motor gear unit	
27	MIXIT main board	
28	MIXIT cover	Makrolon 9415 PC 10%GF FR
29	Terminal cover	Makrolon 9415 PC 10%GF FR

Flanged Version

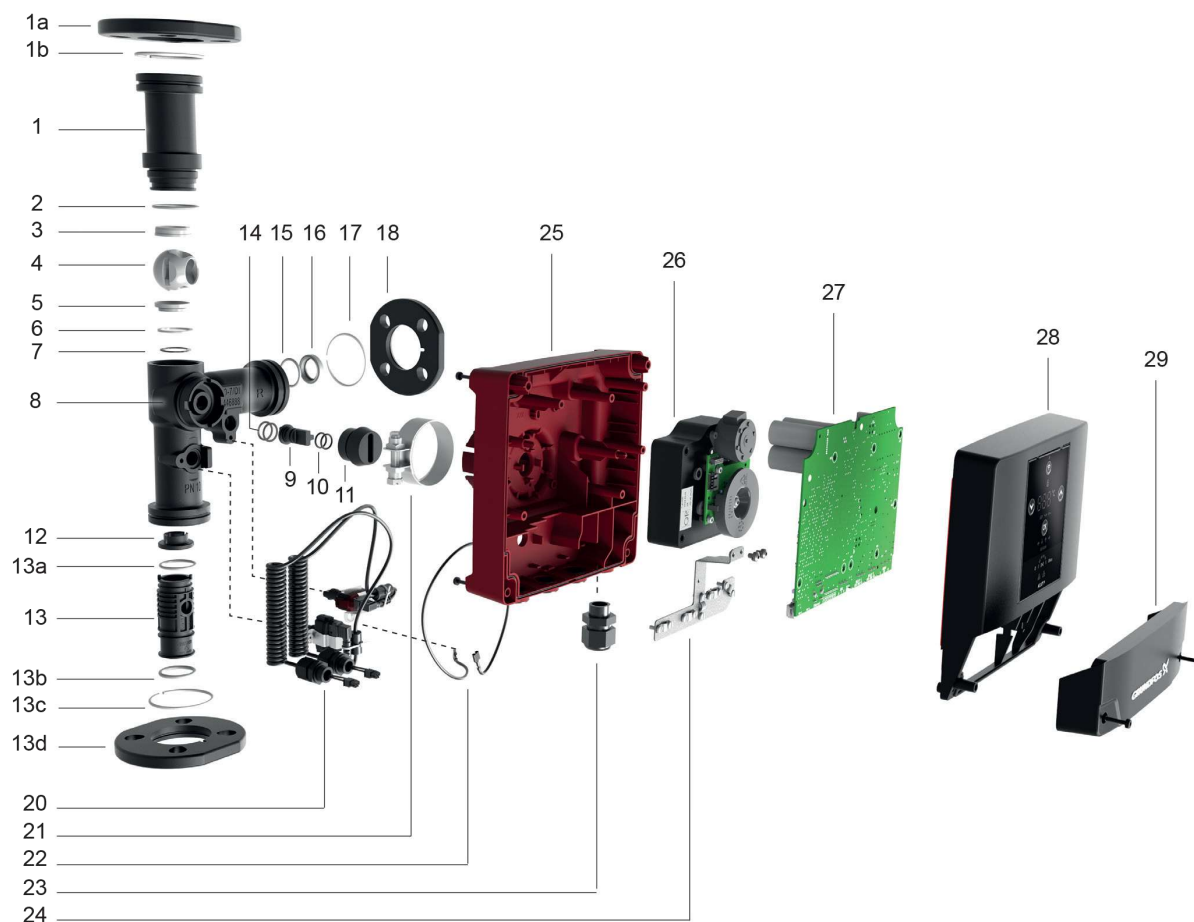

TM080478

Pos.	Description	Material
1	Retainer AB	Cast iron GJS500-7 and CED
1a	Flange	Stainless steel EN 1.4308 and CED
1b	Lock ring d74,6/d5	EN 1.4310
2	O-ring	EPDM (EP70)
3	Seat AB	Carbon reinforced PTFE
4	Ball valve	Brass CW641N, Ni and Cr
5	Seat A	Carbon reinforced PTFE
6	Washer	Stainless steel EN1.4301
7	O-ring	EPDM (EP70)
8	Valve body	Cast iron GJS500-7 and CED
9	Stem	Stainless steel
10	O-rings	EPDM (EP70)
11	Coupling	Brass CW614N
12	Flow restriction disc	PPS 40-GF
13	Flow insert	PPS 40-GF
13a	O-ring	EPDM (EP70)
13b	O-ring	EPDM (EP70)
13c	Lock ring d74,6/d5	EN 1.4310
13d	Flange	Stainless steel EN 1.4308 and CED
14	Bearings for stem	PTFE
15	O-ring	EPDM (EP70)
16	Seat B	Carbon reinforced PTFE
17	Lock ring d74,6/d5	EN 1.4310
18	Flange	Stainless steel EN 1.4308 and CED
20	Sensors	Wetted materials: Corrosion-resistant coating, EPDM, PPS

Pos.	Description	Material
21	Clamp	Stainless steel EN1.4301
22	Grounding cable	
23	Cable gland	PA
24	Earth plate	Stainless steel
25	Control box housing	Makrolon 9415 PC 10%GF FR
26	Motor gear unit	
27	MIXIT main board	
28	MIXIT cover	Makrolon 9415 PC 10%GF FR
29	Terminal cover	Makrolon 9415 PC 10%GF FR

Ball valve

MIXIT leads water through port A and lets return water in through port B. The mixed water is then let out through the AB port.



Two-way valve with a shunt

By turning the ball valve in a clockwise direction (I-II-III), port A goes from closed to fully open position and vice-versa in a counterclockwise direction (III-II-I). Port B is always fully open and works as a shunt.

Three-way valve

By adjusting the angle of the ball valve in a counterclockwise direction (I-II-III), port A goes from closed to a fully open position, while port B goes from fully open to closed. The opposite happens when the ball valve is adjusted in a clockwise direction (III-II-I).

Two-way and three-way valves

Due to the unique design of the ball valve, MIXIT can be configured both as a two-way valve and a three-way valve. MIXIT does this by simply changing the opening direction of the ball valve.

Two- and three way operation

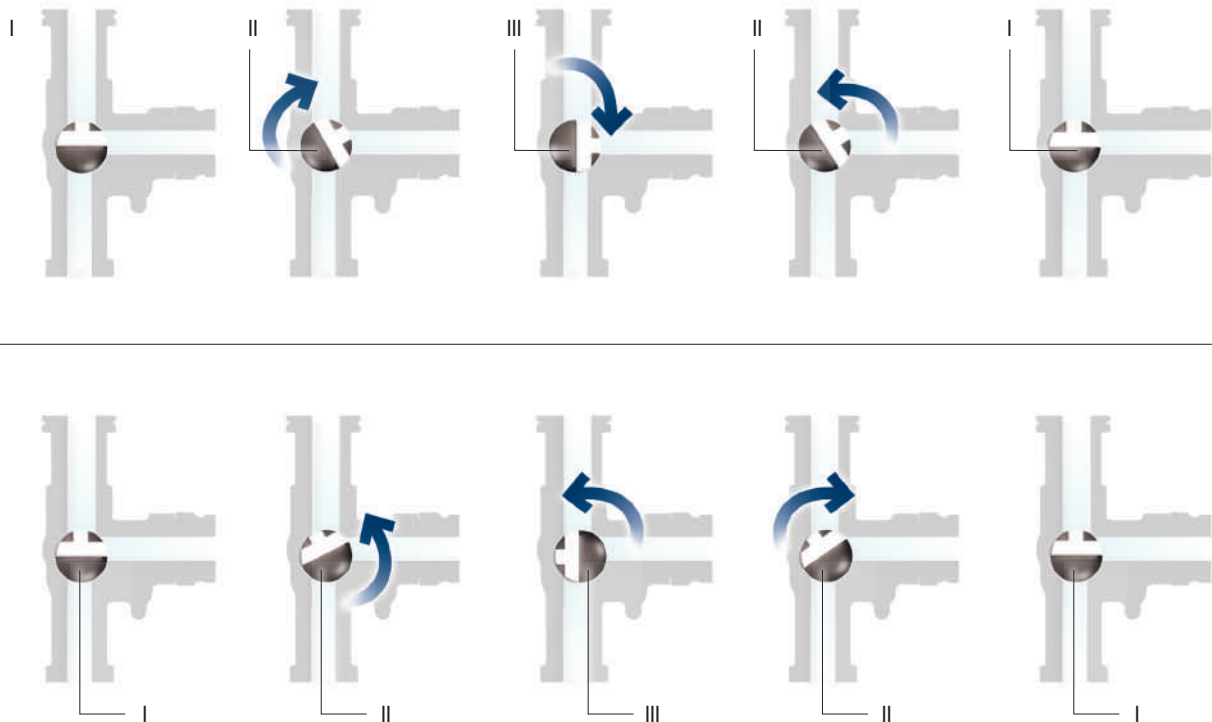

Top: two-way operation, bottom: three-way operation

Non-return valve

Threaded versions of MIXIT are factory fitted with a non-return valve. For flange versions, non-return valves are available as accessories and are installed externally at the B-port of the MIXIT unit.

The non-return valve ensures that the liquid flows through the pipe in the correct direction where pressure conditions may otherwise cause a reversed flow.

Some systems require a non-return valve, while other systems might not need it. Therefore, the non-return valve can easily be removed to eliminate any unwanted resistance.

Seats

The PTFE seats in MIXIT offer low friction and a high level of tightness. The EPDM O-rings located between the valve housing and seats in ports A and B create compression making the valve less sensitive to wear and tolerances.

Sensors

The valve has integrated flow and temperature sensors. The Integrated Temperature sensor Standard (ITS2) measures the temperature at the B-port. The Vortex Flow sensor Standard (VFS) measures the flow at the A-port, which is used for the pressure independent functionality. Additionally, it measures the temperature at the A-port. Due to these sensors, the high mechanical resolution of the control valve and the construction of the ball valve, it is possible for MIXIT to operate effectively with a lower pressure difference than traditional mechanical solutions. When paired with a MAGNA3/TPE3 pump, MIXIT is able to use all the pump parameters.

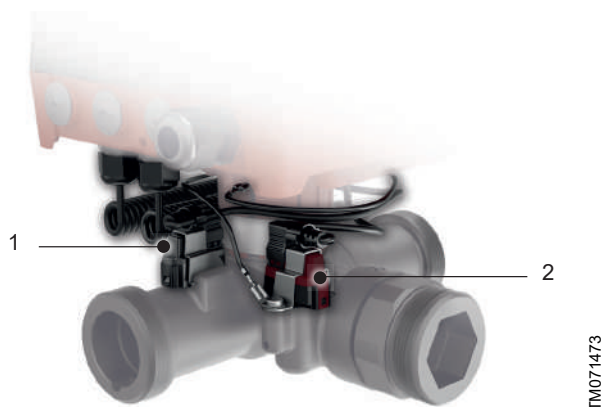

Pos.	Description
1	Vortex Flow sensor Standard (VFS)
2	Integrated Temperature sensor Standard (ITS2)

Related information

[Integrated Temperature sensor Standard \(ITS2\)](#)
[Vortex Flow sensor Standard \(VFS\)](#)

Vortex Flow sensor Standard (VFS)

The Vortex Flow sensor Standard (VFS) is a combined flow and temperature sensor (two-in-one) from Grundfos Direct Sensors™. The sensor is based on the principle of vortex shedding behind a bluff body. The VFS sensor is fully compatible with wet, aggressive liquids. The sensor

is based on a Micro Electro-Mechanical System (MEMS) sensing technology in combination with the corrosion-resistant Silicoat® coating technology on the sensor chip.

Integrated Temperature sensor Standard (ITS2)

The Integrated Temperature sensor Standard (ITS2) is a temperature sensor from Grundfos Direct Sensors™. The ITS2 sensor is fully compatible with wet, aggressive liquids. The sensor is based on a Micro Electro-Mechanical System (MEMS) sensing technology in combination with the corrosion resistant Silicoat® coating technology on the sensor chip.

6. Functions overview

All needed functions and controls of a mixing loop are built into MIXIT. Not only does this mean simple implementation and installation, but also an efficient, reliable and smooth operation.

	MIXIT valve unit	MIXIT DYNAMIC valve unit	DYNAMIC upgrade	CONNECT upgrade	
Standard functions	Temperature controller	•	•		
	Underfloor overheat protection (for underfloor heating systems)	•	•		
	Coil preheat and frost protection (for air handling unit systems)	•	•		
	Frost protection (cooling and combined applications)	•	•		
	Pump control modes ³⁾				
	• AUTOADAPT • Proportional pressure • Constant pressure • Constant flow • Constant curve/constant speed	•	•		
Eco schedule and warm-weather shutdown	Weather curve	•	•		
		•	•		
Eco functions	Pressure independence		•	•	
	Energy monitor		•	•	
	Balancing limiters				
	• Supply flow limit • Return temperature limit • Thermal power limit • Differential temperature limit		•	•	
Monitoring and control	Grundfos BuildingConnect Free Monitoring	•	•	•	
	Grundfos BuildingConnect Professional			•	
	Fieldbus integration (BACnet and Modbus)			•	

³⁾ These modes are not available for all applications.

The standard functions are always included. The DYNAMIC and CONNECT upgrades can be combined.

MIXIT, valve unit variant

The functions in MIXIT are standard and are mainly suited for three-way installations in large buildings, such as schools, with no need for monitoring, pressure independence or balancing.

MIXIT gives access to Grundfos BuildingConnect Free Monitoring.

MIXIT can be upgraded with DYNAMIC and CONNECT.

MIXIT DYNAMIC, valve unit variant

MIXIT DYNAMIC includes balancing limiters functions, pressure independence as well as the Free Monitoring version of Grundfos BuildingConnect. This valve unit is recommended for pressurised applications, where pressure independence, energy monitoring and flow or energy balancing are required.

MIXIT DYNAMIC can be upgraded with CONNECT.

The energy monitoring functionality is automatically activated when MIXIT is upgraded with the DYNAMIC upgrade or if the MIXIT unit is a MIXIT DYNAMIC.

DYNAMIC upgrade

The DYNAMIC upgrade offers balancing limiters functions and pressure independence. Also, it gives access to the Grundfos BuildingConnect Free Monitoring solution.

The DYNAMIC and CONNECT upgrades can be combined.

CONNECT upgrade

CONNECT is suitable when MIXIT operates as a subsystem in large installations where a BMS system is already in place. The upgrade enables you to connect MIXIT to a building management system via fieldbus (BACnet or Modbus) and gives access to Grundfos BuildingConnect Professional.

The DYNAMIC and CONNECT upgrades can be combined.

Related information

[MIXIT in a radiator heating system](#)

[MIXIT in a underfloor heating system](#)

[MIXIT in an air handling unit system](#)

Temperature controller

From factory MIXIT is configured so that the temperature response of the system in most cases corresponds to the centre graph in the figure. This is the ideal response, however, in some cases it may be necessary to adjust it.

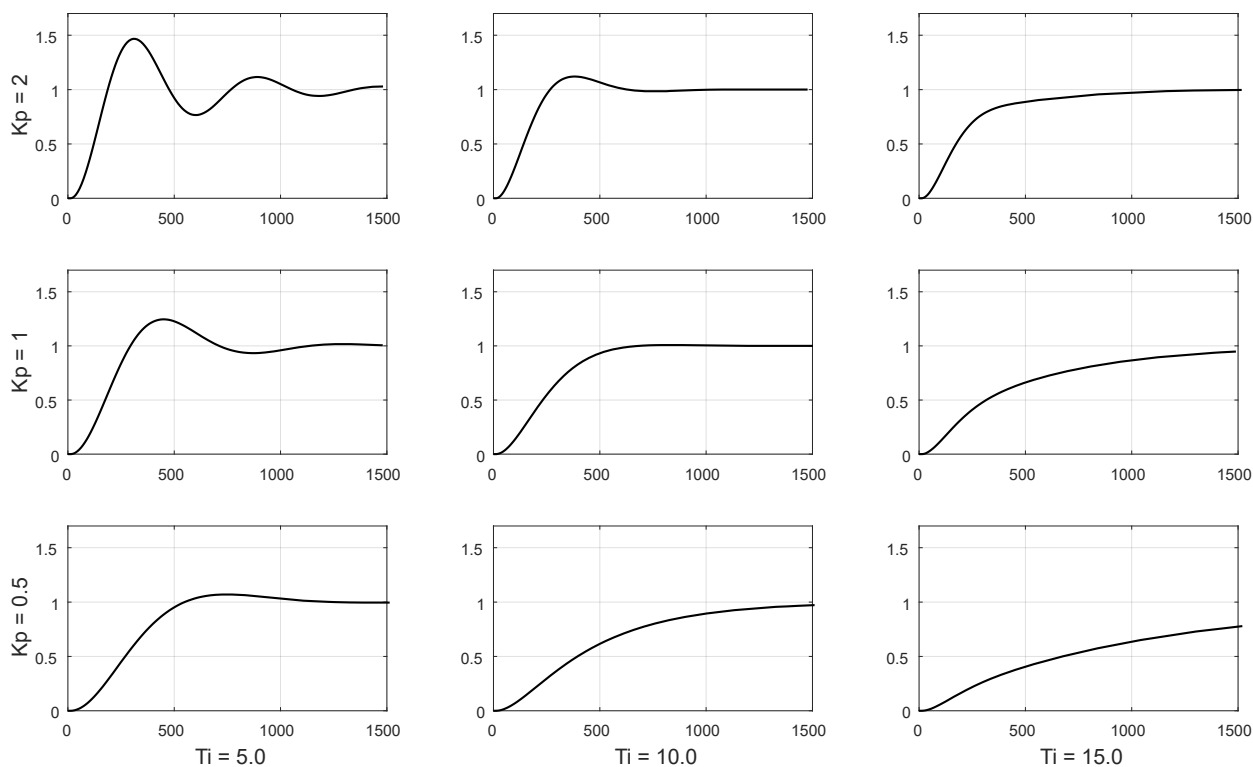

TM077581

Typical responses to a step input for PI controlled systems such as MIXIT

By increasing the proportional gain (K_p) of the controller, as shown in the top row in the figure, the response rises more rapidly. If the gain is too high, undamped oscillations occur. If the gain is even higher, the oscillation of the temperature will continue, causing instability. By decreasing the proportional gain of the controller, as shown in the bottom row in the figure, the response becomes slower.

By increasing the integral time (T_i), as shown in the right column in the figure, the response takes longer time to reach the setpoint. Decreasing the integral time has the opposite effect, which is shown in the left column in the figure.

Underfloor overheat protection

When selecting the application type **Underfloor heating**, you can choose to activate the floor overheat protection function.

By defining a maximum forward flow temperature, you ensure that the temperature will never exceed the given value, thus protecting the floor from overheating.

Heating coil preheat and frost protection

When choosing the application type **Heating coil**, you can activate the coil preheat and frost protection functions.

Coil preheat

With MIXIT you can preheat the coil before allowing the fan to start.

In Grundfos GO Remote you define a return temperature threshold to indicate when the coil is heated. By preheating the coil a higher level of comfort is ensured which also minimises the risk of frost in the coil.

Frost protection

You can protect the coil from freezing by defining an air and return flow temperature. If the temperature falls below one of the two temperature limits, MIXIT will react by fully opening the valve in order to circulate hot water in the system.

The return flow temperature is measured by the sensor in port B of MIXIT. To measure the air temperature, you will need to install a temperature sensor in the coil.

Frost protection for cooling

When choosing the application type **Cooling**, you can activate the frost protection functions.

Frost protection

You can protect the coil from freezing by defining a return flow temperature. If the temperature falls below temperature limit, MIXIT will react by fully opening the valve in order to circulate water in the system.

The return flow temperature is measured by the sensor in port B of MIXIT.

Frost protection for combined heating and cooling

When choosing the application type **Combined heating and cooling**, you can activate the frost protection functions.

Frost protection

Frost protection is available for both heating and cooling system separately. You can protect the heating and cooling system from freezing by defining a return flow temperature. If the temperature falls below the temperature limit, MIXIT will react by fully opening the valve in order to circulate water in the system.

The return flow temperature is measured by the sensor in port B of MIXIT.

Pump control modes

When MIXIT is connected to the pump, the control mode is by default set to the control mode that best suits the application in which MIXIT operates. You can choose between five different control modes:

- **AUTOADAPT**
During operation, the pump automatically makes the necessary adjustment to the actual system characteristic. Recommended for most heating systems.
- **Proportional pressure**
Default control mode for radiator heating systems. Typically used in systems with relatively large pressure losses in the distribution pipes.
- **Constant pressure**
Default control mode for underfloor heating systems. We recommend this control mode in systems with relatively small pressure losses such as underfloor heating systems.
- **Constant curve/constant speed**
Default control mode for air handling units. The pump operates according to a constant curve and is suitable for systems where both a constant flow rate and a constant head are required.
- **Constant flow**
The pump maintains a constant flow in the system independently of the head. We recommend that you use this control mode in air handling unit systems.
- In the cooling system, a pump can operate on all five different control modes.

Weather curve

With the weather curve function activated, the product automatically adjusts the mixed flow temperature according to the outdoor temperature.

Weather curve is set by means of a five-point temperature curve. The curve allows you to predefine five liquid temperature setpoints. MIXIT interpolates between the setpoints and automatically adjusts the liquid temperature accordingly to compensate for the energy (heating/cooling) demand.

For heating-coil applications, the curve defines the air temperature.

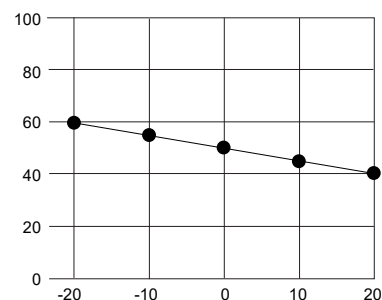

TM072831

Example of five point temperature curve. Y axis: Setpoint [°C]. X axis: Outdoor temperature [°C].

Eco schedule

In some applications it can be useful to predefine a start and stop schedule and apply an automatic temperature setback function in order to minimise consumption, and thereby energy costs.

With the Eco schedule you can configure start and stop intervals on a weekly basis as well as set single events.

Temperature setback and system turn off

A temperature setback can be defined for the period in which MIXIT runs on Eco schedule. In this period, MIXIT sets the normal operation temperature back with the number of degrees set in Grundfos GO Remote.

MIXIT can also be set to turn off during the Eco period.

Warm-weather shutdown

When a defined maximum outdoor temperature has been surpassed one to three days in a row, MIXIT automatically shuts down and the pump stops. MIXIT and the pump start again when the average outdoor temperature falls below the temperature limit one to three days in a row, depending on the defined settings.

The temperature and number of days are set in Grundfos GO Remote.

The temperature signal must be available from either an outdoor temperature sensor or fieldbus.

Once the function has been activated or the function settings have been changed, MIXIT will immediately act accordingly.

Pressure independence

If the differential pressure varies on the primary side, the relation between the valve opening and the flow through the valve changes. These changes will affect the control performance and can result in slow temperature responses or fluctuating temperatures. By comparing the valve opening with the forward and return temperature measurements, MIXIT supports such changes, along with changes in the pump flow, supply temperature, and return temperature. This allows the system to perform optimally, which increases both comfort and energy efficiency.

Supply flow limit

To ensure enough primary flow to all installed MIXIT systems, you can balance each system according to its heat demand. This is done by limiting the primary flow through the valve.

As illustrated below, the primary flow of the valve (Q_{max}) is adjusted to the maximum flow of the system (1). Hereby a new working range (2) is set for the valve. The working range is configured during setup without any mechanical adjustments.

Supply source setpoint

Supply source setpoint can only be configured using Grundfos Go remote

The supply source setpoint function allows the possibility to control the output temperature of the boiler (in heating systems) or compressor (in cooling systems). The benefit for controlling the supply source temperature is to reduce the energy losses in the pipes by running the source at the temperature needed in the load +/- an offset. The function can be used with 1 MIXIT unit controlling the supply source setpoint or in a cascade with several MIXIT units in series (daisy chain) where the highest/lowest temperature demand is used as supply setpoint depending on heating/cooling. Setup of the function is done via the Grundfos GO remote with possibility to offset the setpoint for both heating and cooling

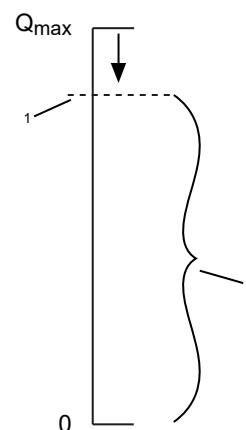

TM072799

Pos.	Description
1	Balanced maximum flow, system
2	New working range for valve

The valve is adjustable within its flow range (K_{vs} value). The table in [2. Performance range](#) shows the flow ranges and K_{vs} values for each MIXIT variant.

If the CONNECT upgrade is installed, the primary flow data can be provided to a building automation system for monitoring purposes.

Related information

[2. Performance range](#)

Return temperature limit

Return temperature limit is commonly used to keep a high efficiency at the heat source and to protect the production plant.

The integrated temperature sensor in MIXIT monitors the return temperature. By using the return temperature limit function, you are able to keep the temperature below a set limit for heating and above a set point for cooling.

Thermal power limit

MIXIT can be configured to limit the thermal power delivered by the mixing loop. The power limiter automatically limits the valve opening whenever the configured power limit is exceeded.

Differential temperature limit

MIXIT can be configured to limit the temperature difference between the primary supply and return flow. This is especially useful in district heating where the payment tariff can depend on the differential temperature.

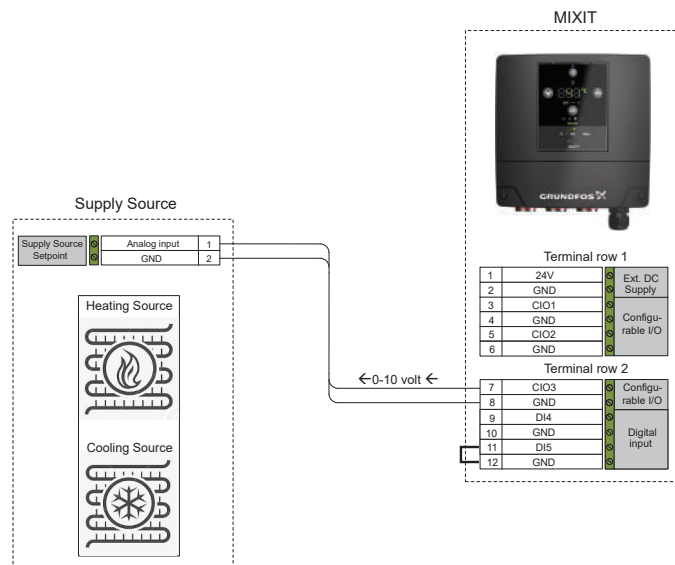

TM086288

Local supply source setpoint

Daisy chain

During Daisy chain setup , CIO2 is not available for Air temperature feed back .

In Daisy chain, multiple MIXITs are connected together to get the maximum(heating) or minimum(cooling) supply source setpoint. It is possible to connect the analog output of supply source setpoint from one MIXIT to the analog input on an another MIXIT and then enable the daisy chain functionality. This selects the maximum(heating) or minimum(cooling) value of the supply source setpoint found on the MIXIT compared with the value on the analog input. The resulting setpoint of the comparison is then sent out on the analogue output. Multiple MIXITs can be connected like this to find the maximum or minimum setpoint for all of them. It is required that all MIXITs connected in a daisy chain will run the same heating/cooling/combined application setup. For combined application setup, then all units must use the same switch over signal.

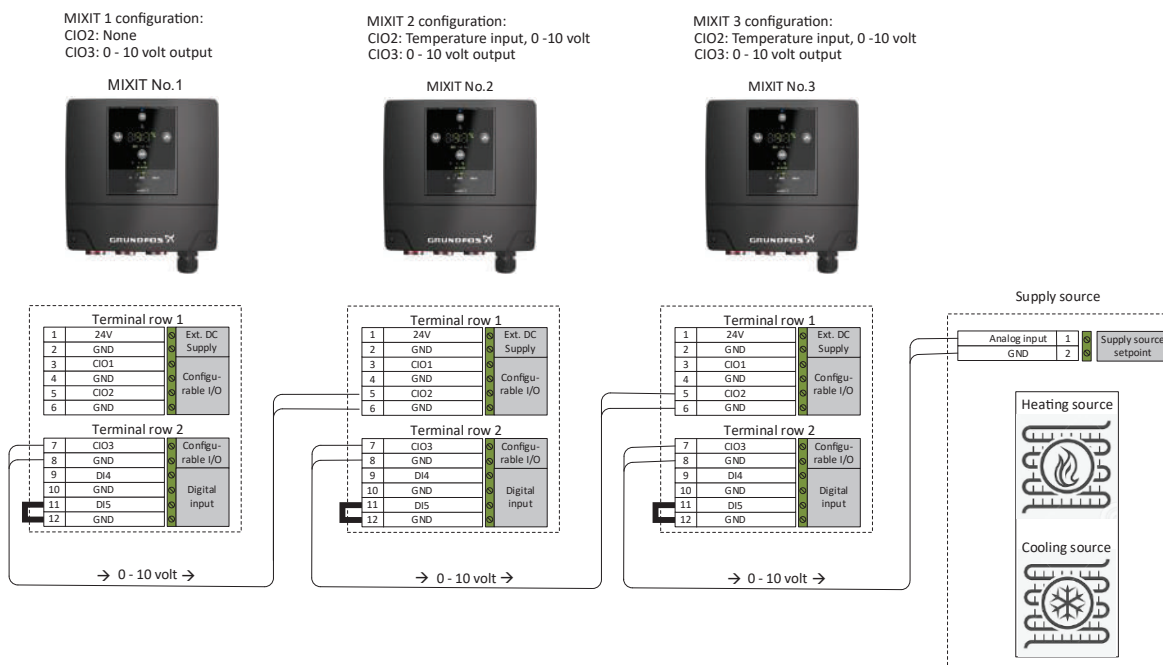

TM086153

Daisy chain supply source set point

Energy monitor

With the energy monitor function it is possible to monitor the energy consumption in individual zones. This function does not require any additional sensors or any additional settings to the system.



The function is automatically activated when MIXIT is upgraded with the DYNAMIC upgrade or if the MIXIT unit is a MIXIT DYNAMIC.

The calculated value cannot be used for billing purposes. However, it is perfect for optimisation purposes in order to prevent excessive energy costs caused by system imbalances.

The thermal power is calculated based on the measurements from the two temperature sensors and the flow sensor. At normal working conditions the tolerance of the thermal power is +/- 10% relative to the operating point. However, some conditions can influence the thermal power:

- Low supply flow. The built-in flow sensor has a minimum flow limit for measuring flow and below this limit the flow is estimated based on the temperature measurements and the flow estimation from the pump.
- Low temperature difference. The temperature sensors are not paired, so the tolerance on the temperature measurements will be more dominant at low temperature difference. The tolerances of the flow and temperature measurements can be found in section Sensor data.

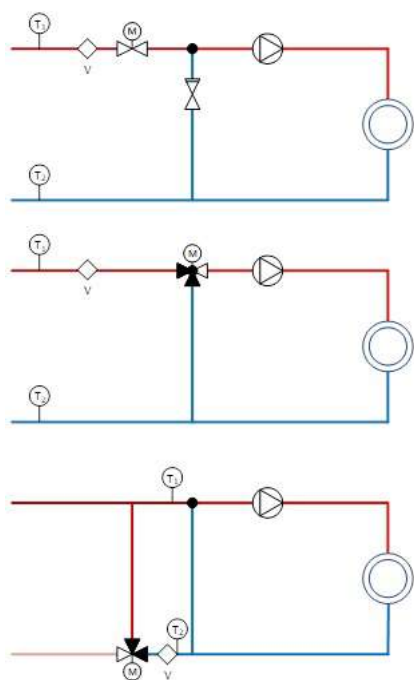

MIXIT hydraulic configurations placement of sensors

TM086353

Energy monitoring register

Registers are available for cloud, Grundfos GO Remote and via fieldbus.

- Life time, last year and year to date counters are available on GO Remote
- Life time counters are available via fieldbus

The registers for energy monitoring are shown in below table.

Name	Content
Heat Volume V_H	ΣV_H
Cooling Volume V_C	ΣV_C
Heat Energy	$\Sigma V_H (T_1 - T_2) \rho C_p^*$
Cooling Energy	$\Sigma V_C (T_2 - T_1) \rho C_p^*$
Volume weighted average T1, Heating (inlet)	$\Sigma V_H T_1$
Volume weighted average T2, Heating (outlet)	$\Sigma V_H T_2$
Volume weighted average T1, Cooling (inlet)	$\Sigma V_C T_1$
Volume weighted average T2, Cooling (outlet)	$\Sigma V_C T_2$

* The actual implementation calculates uses enthalpy.

Registers									
	Lifetime			Last year			This year		
	GOR	Field bus	GBC	GOR	Field bus	GBC	GOR	Field bus	GBC
Heat Volume V_H	X	X	X	X			X		
Cooling Volume V_C	X	X	X	X			X		
Heat Energy	X	X	X	X			X		
Cooling Energy	X	X	X	X			X		
Volume weighted average T1, Heating (inlet)	X	X	X	X			X		
Volume weighted average T2, Heating (outlet)	X	X	X	X			X		
Volume weighted average T1, Cooling (inlet)	X	X	X	X			X		
Volume weighted average T2, Cooling (outlet)	X	X	X	X			X		

Calculation of average temperatures using yearly readings

Reading date	Volume (V_H)	Volume weighted average T1, Heating (inlet) ($\Sigma V_H T_1$)	Average of inlet ($V_H / (\Sigma V_H T_1)$)	Volume weighted average T2, Heating (outlet) ($\Sigma V_H T_2$)	Average of outlet ($V_H / (\Sigma V_H T_2)$)
01-07-2022	534,3	48236		18654	
01-07-2021	236,9	20123		7651	
Yearly consumption	297,4	28113	94,5	11003	37,0

ID	Object name	Access	Description
AI,7*	Data Heating Energy [kWh]	R	Accumulated heating energy in total lifetime. Reset via BO,6 (Reset Accumulated Counters).
AI,8*	Data Heating Power [kW]	R	Current thermal power for product running in heating mode.
AI,9*	Data VolWeightAvgT1Heat [$^{\circ}\text{C m}^3$]	R	Accumulated cooling energy in total lifetime. Reset by BO, 6 (Reset Accumulated Counters).
AI,10*	Data VolWeightAvgT2Heat [$^{\circ}\text{C m}^3$]	R	Current thermal power for product running in cooling mode.
AI,11*	Data VolWeightAvgT1Cool [$^{\circ}\text{C m}^3$]	R	Numerical value of forward pipe and return pipe differential temp. Used for heat transfer calculation.
AI,39*	Data HeatingVolume [m^3]	R	Totally pumped heating volume
AI,40*	Data CoolingVolume [m^3]	R	Totally pumped cooling volume
AI,41*	Data VolWeightAvgT1Heat [$^{\circ}\text{C m}^3$]	R	Totally volume weighted average for T1, Heating (Inlet)

ID	Object name	Access	Description
AI,42*	Data VolWeightAvgT2Heat [$^{\circ}\text{C m}^3$]	R	Totally volume weighted average for T2, Heating (Outlet)
AI,43*	Data VolWeightAvgT1Cool [$^{\circ}\text{C m}^3$]	R	Totally volume weighted average for T1, Cooling (Inlet)
AI,44*	Data VolWeightAvgT2Cool [$^{\circ}\text{C m}^3$]	R	Totally volume weighted average for T2, Cooling (Outlet)

Address	Register name	ModBus unit	R/W	Description
00305	MeasuredData.HeatingPower	1 kW	R	Current thermal power for product running in heating mode.
00306	MeasuredData.HeatingTempDifference	0.01 $^{\circ}\text{C}$	R	Numerical value of forward pipe and return pipe differential Temperature. Used for heat transfer calculation.
00325	MeasuredData.HeatingEnergyHI	1 kWh	R	Accumulated heating energy in total lifetime. Reset via 00101.3 (Reset Accumulated Counters).
00326	MeasuredData.HeatingEnergyLO	1 kWh	R	Accumulated heating energy in total lifetime. Reset via 00101.3 (Reset Accumulated Counters).

Address	Register name	ModBus unit	R/W	Description
00327	MeasuredData.CoolingPower	1 kW	R	Current thermal power for product running in cooling mode.
00339	MeasuredData.HeatingVolumeHI	0.01 m ³	R	Accumulated heating volume in total lifetime. Reset via 00101.3 (Reset Accumulated Counters).
00340	MeasuredData.HeatingVolumeLO	0.01 m ³	R	Accumulated heating volume in total lifetime. Reset via 00101.3 (Reset Accumulated Counters).
00341	MeasuredData.CoolingVolumeHI	0.01 m ³	R	Accumulated cooling volume in total lifetime. Reset via 00101.3 (Reset Accumulated Counters).
00342	MeasuredData.CoolingVolumeLO	0.01 m ³	R	Accumulated cooling volume in total lifetime. Reset via 00101.3 (Reset Accumulated Counters).
00343	MeasuredData.CoolingEnergyHI	1 kWh	R	Accumulated cooling energy in total lifetime. Reset via 00101.3 (Reset Accumulated Counters).
00344	MeasuredData.CoolingEnergyLO	1 kWh	R	Accumulated cooling energy in total lifetime. Reset via 00101.3 (Reset Accumulated Counters).
00345	MeasuredData.VolWeightAvgT1HeatingHI	0.01 °C m ³	R	Total volume weighted average for T1, Heating (Inlet). Reset via 00101.3 (Reset Accumulated Counters).
00346	MeasuredData.VolWeightAvgT1HeatingLO	0.01 °C m ³	R	Total volume weighted average for T1, Heating (Inlet). Reset via 00101.3 (Reset Accumulated Counters).
00347	MeasuredData.VolWeightAvgT2HeatingHI	0.01 °C m ³	R	Total volume weighted average for T2, Heating (Outlet). Reset via 00101.3 (Reset Accumulated Counters).
00348	MeasuredData.VolWeightAvgT2HeatingLO	0.01 °C m ³	R	Total volume weighted average for T2, Heating (Outlet). Reset via 00101.3 (Reset Accumulated Counters).
00349	MeasuredData.VolWeightAvgT1CoolingHI	0.01 °C m ³	R	Total volume weighted average for T1, Cooling (Inlet). Reset via 00101.3 (Reset Accumulated Counters).
0035	MeasuredData.VolWeightAvgT1CoolingLO	0.01 °C m ³	R	Total volume weighted average for T1, Cooling (Inlet). Reset via 00101.3 (Reset Accumulated Counters).
00351	MeasuredData.VolWeightAvgT2CoolingHI	0.01 °C m ³	R	Total volume weighted average for T2, Cooling (Outlet). Reset via 00101.3 (Reset Accumulated Counters).
00352	MeasuredData.VolWeightAvgT2CoolingLO	0.01 °C m ³	R	Total volume weighted average for T2, Cooling (Outlet). Reset via 00101.3 (Reset Accumulated Counters).

Grundfos GO Remote menu:

Grundfos Go displays the register values. It displays the values of the current system in use, ie. heating or cooling.

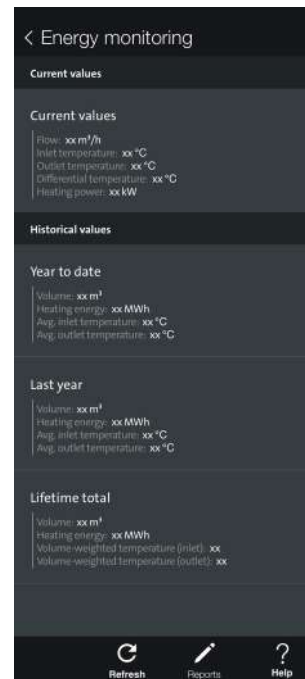

Energy monitoring display in heating/cooling application

In Combined heating/cooling application the user is able to switch between parameters for heating or cooling. The values in the energy monitoring screen reflect the actual status of the system, if currently heating, it shows the heating parameters and vice versa.

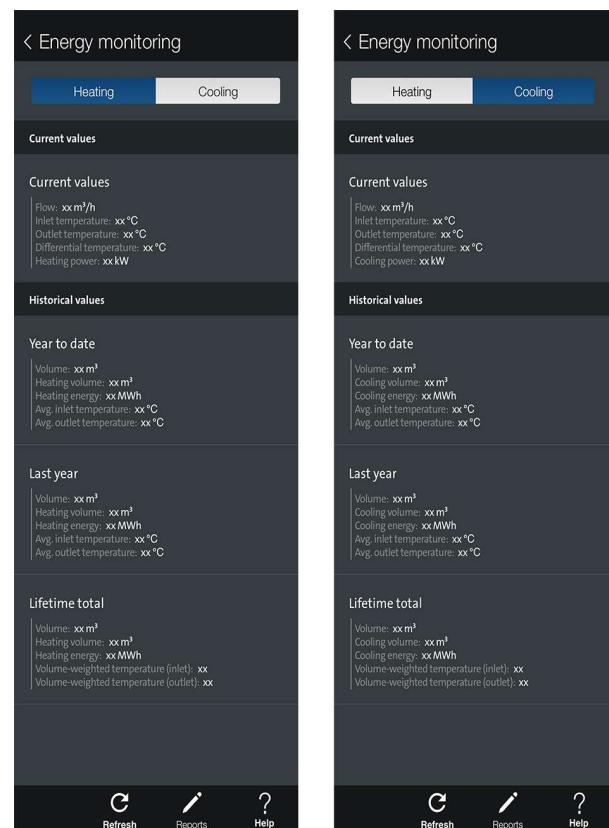

Energy monitoring display in Combined heating/cooling application

Grundfos BuildingConnect

With Grundfos BuildingConnect you can monitor your MIXIT system from the office or on the go. Grundfos BuildingConnect offers realtime monitoring, including alarm and warning notifications.

With Grundfos BuildingConnect Professional you get access to even more monitoring points as well as the ability to control the system.

Fieldbus integration

The integrated fieldbus makes it easy to incorporate MIXIT into any building management system (BMS). MIXIT provides all data points through one data connection because the valve, pump, controller and sensors are one complete system. No I/O is required in the sub controller, and if the integrator uses an IP-based fieldbus, the sub controller is redundant.

Furthermore, the integrated fieldbus offers:

- A cost-effective installation due to less wiring
- Up to 170 data points delivering all available objects from MAGNA3/TPE3 and MIXIT
- Performance/response tests offsite
- Offsite balancing and optimisation without having to manually change valve positions
- Logging of parameters such as:
 - supply temperature, mixed temperature and return temperature
 - flow estimation
 - valve position
 - power estimations
 - warnings and alarms.

The integration can be done via BACnet IP, BACnet MS/TP, Modbus TCP or Modbus RTU. The connectivity is configured via the Grundfos GO Remote app. When the fieldbus connection is established, the remaining configuration can be done via the bus system setup.

Built-in line termination

If MIXIT is the last device on the fieldbus cable, a built-in terminal resistor can be activated via an on/off switch to avoid noise on the cable. Note that this only applies to BACnet MS/TP and Modbus RTU connections.

Functional profiles

There are two functional profiles available for MIXIT covering all four fieldbus connections. The documents are available via Grundfos Product Center, <http://product-selection.grundfos.com>, or by scanning the QR codes listed below.

For all fieldbus related documents see www.grundfos-eica.com

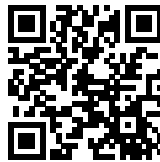
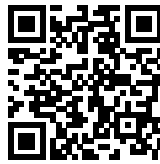
Document	Product number	QR code
BACnet IP and BACnet MS/TP	99258495	
Modbus TCP and Modbus RTU	99349159	

QR99258495

QR99349159

Related information

[System integration](#)

[Terminal connections overview](#)

[Setting up the product using Grundfos GO Remote](#)

7. Installation

MIXIT allows you to build a complete mixing loop in only two steps.

1. Install MIXIT and the pump in the pipe system.

You must install MIXIT and the pump in such a way that they are not stressed by the pipes. The two units may be suspended directly in the pipes, provided that the pipes can support them.

To ensure sufficient cooling of motor and electronics, observe the following:

- Position MIXIT and the pump in such a way that sufficient cooling is ensured.
- The ambient temperature must not exceed 50 °C.

For thread version

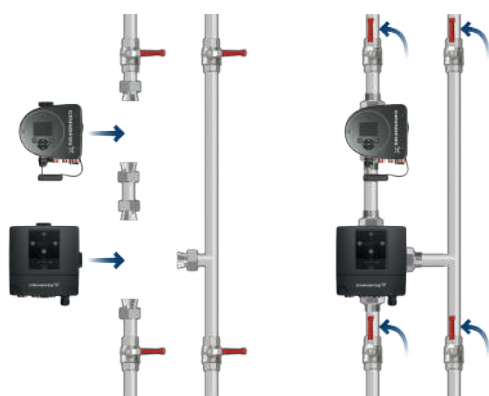

TM071471

For flanged version

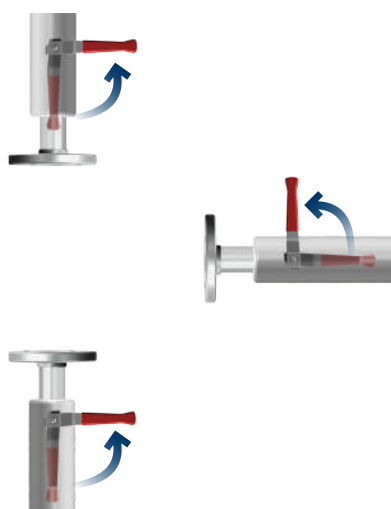

TM080489

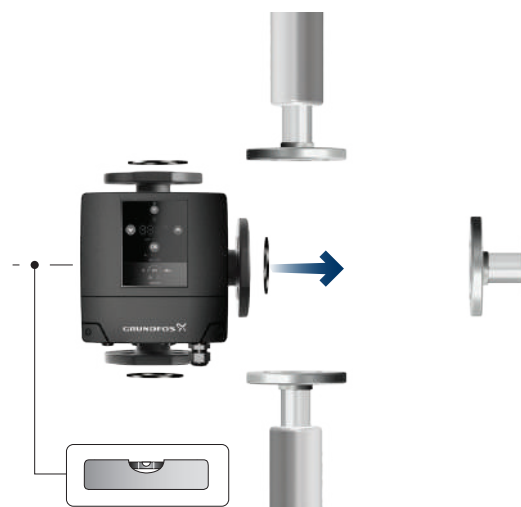

TM080490

2. Connect MIXIT and the pump to the power supply. Once connected, the installation of MIXIT is complete.

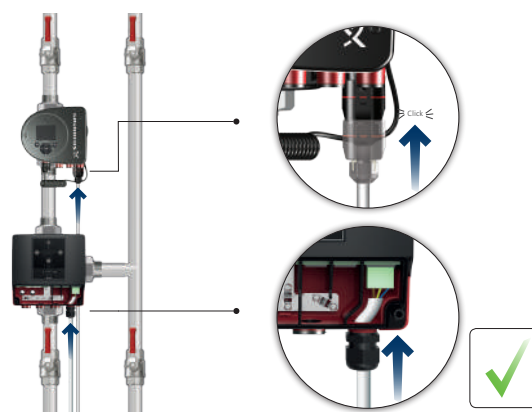

TM071472

Insulating shells

In heating systems the insulating shells supplied with MIXIT must be fitted as part of the installation to reduce the heat loss.

Electrical installation

All electrical connections must be carried out by a qualified electrician in accordance with local regulations.

- The system must be connected to an external main switch.
- The system must always be correctly earthed.
- The system requires no external motor protection.
- The system incorporates thermal protection in order to prevent slow overloading and blocking.

MIXIT has a digital input that can be used for external control of start/stop of both the pump and MIXIT without switching the power supply on/off. We do not recommend that the pump is started and stopped on its own without MIXIT being started and stopped as well.

Related information

[Cable requirements](#)

Orientations

MIXIT can be installed both horizontally and vertically. Normally, MIXIT and the pump will be mounted in line.

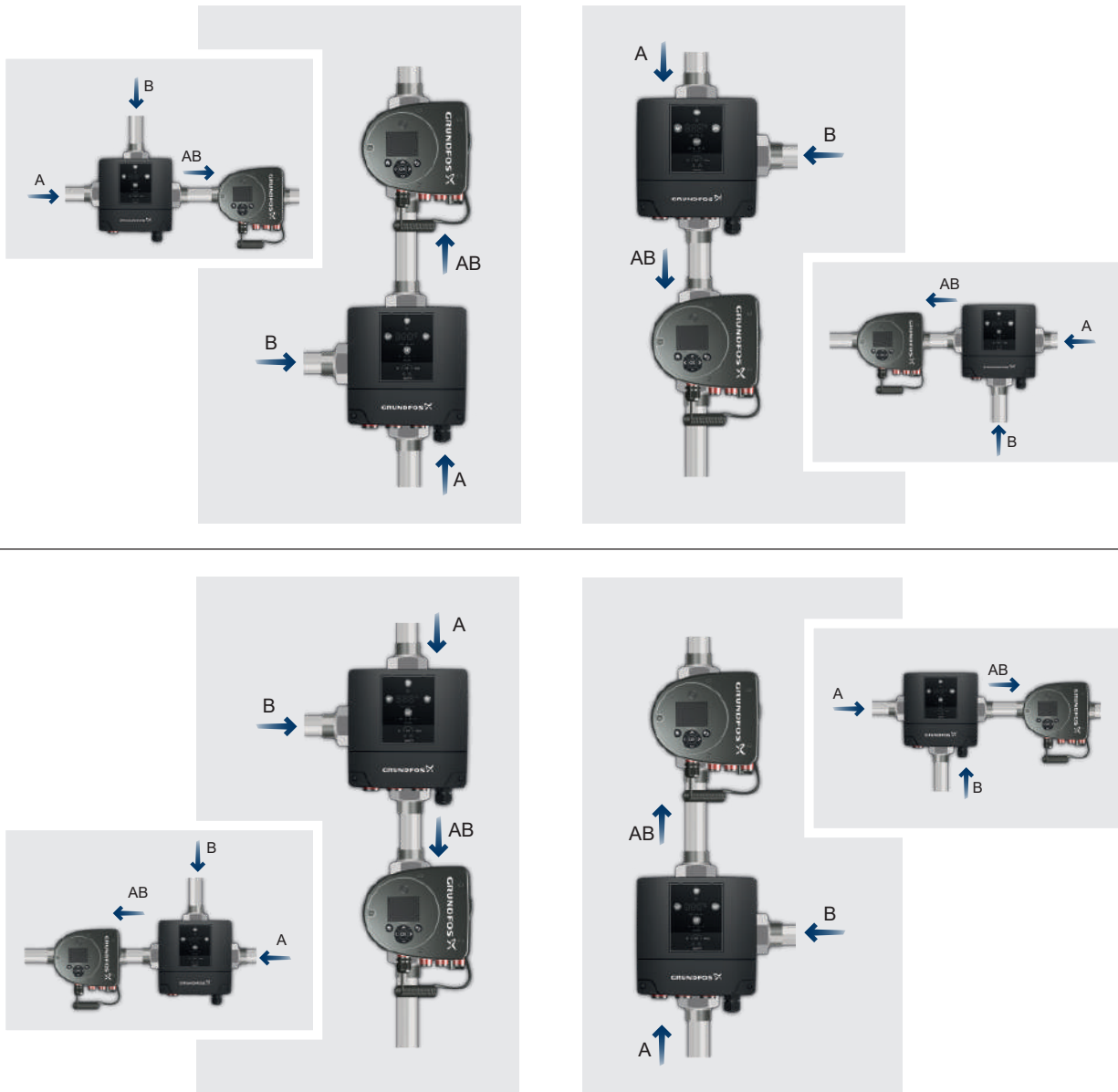

TM071474

MIXIT installation orientations with indication of flow direction. Top: MIXIT with left B port orientation. Bottom: MIXIT with right B port orientation.

Related information

2. Performance range

Terminal connections overview

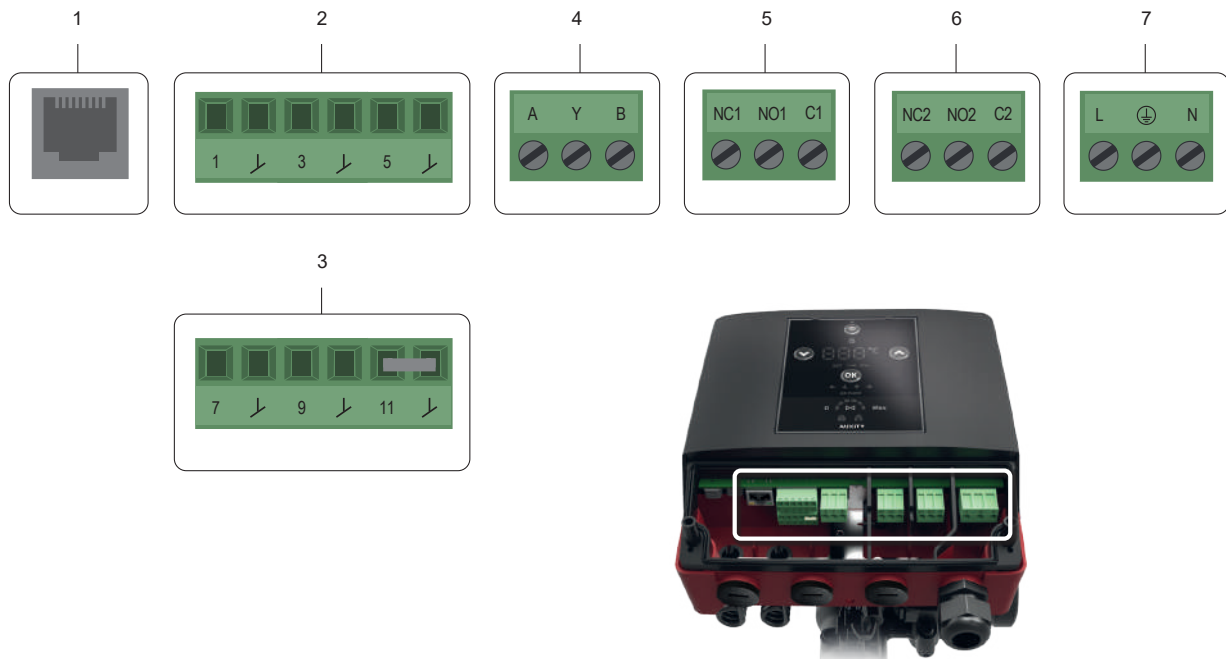

TM071470

Pos.	Description
1	Ethernet RJ45 (BACnet IP, Modbus TCP)
2	Configurable I/O
3	Configurable I/O
4	RS485 transceiver (BACnet MS/TP, Modbus RTU)
5	Relay 1
6	Relay 2
7	Mains supply. Carry out the electrical connection and protection according to local regulations.



The terminals are coded in such a way that the relay terminal plugs cannot be used in the RS485 input and the configurable inputs and outputs cannot be switched around.

Related information

- [MIXIT in a radiator heating system](#)
- [MIXIT in a underfloor heating system](#)
- [MIXIT in an air handling unit system](#)
- [Fieldbus integration](#)

8. Operating the product

Operating panel for MIXIT



TM071469

Po s.	Description
1	<p>Connect button for connecting the valve unit with the pump and connecting MIXIT with Grundfos GO Remote.</p> <p>When MIXIT tries to establish contact with either the pump or Grundfos GO Remote, the blue LED flashes. Once connection is established, the LED is permanently on.</p>
2	<p>Locked operating panel</p> <p>This indicates that the operating panel is locked. The panel can be locked and unlocked using Grundfos GO Remote.</p>
3	<p>Temperature indication (setpoint, supply or return temperature)</p> <p>Default mode: None of the three LEDs are lit and the temperature shown is the mixed flow temperature.</p> <p>Indicates which temperature is shown in the display (7). Press the OK button to toggle between the following:</p> <ul style="list-style-type: none">  In the combined mode, if you want to select the cooling, you can manually switch the DI4. SET: Setpoint. Shows the current setpoint. Indicates that the setpoint is being or can be adjusted. To adjust the setpoint use the two arrow buttons. Arrow pointing right: Supply temperature. Lights red in heating systems, blue in cooling systems. Arrow pointing left: Return temperature. Lights blue in heating systems, red in cooling systems. <p>The display returns to its default mode after 12 seconds.</p>
4	<p>AB port orientation</p> <p>This indicates the orientation of the AB port (flow outlet).</p>
5	<p>Valve position</p> <p>This indicates to which degree the valve is open.</p> <p>0 means that the valve is closed. Max. means that the valve is fully open.</p> <p>If a flow limit is configured, this limit will be Max.</p>

Po s.	Description
6	<p>Warning and alarm indication</p> <p>Yellow indicates a warning. The system continues to operate.</p> <p>When a warning occurs, press OK button and hold, then the warning code is presented in the display.</p> <p>Red indicates an alarm. The system stops operating.</p>
7	<p>Temperature/fault code</p> <p>Default mode: Mixed flow temperature.</p> <p>The display shows:</p> <ul style="list-style-type: none"> Temperature setpoint. To adjust the setpoint use the Up and Down buttons. Inlet, outlet or mixed flow temperature (see 3). Fault codes.
8	<p>External control</p> <p>This indicates that MIXIT is being controlled by external communication equipment.</p>

Note: Once the pump and MIXIT are connected, MIXIT takes over and controls the pump. From then on the pump's operating panel is locked. Settings to the system are done via Grundfos GO Remote and the operating panel of MIXIT.



Related information



[Starting up the system](#)

Starting up the system

Once powered up, the pump and the MIXIT unit can be started. Starting up the product is done in four simple steps.

Shown with Magna Pump

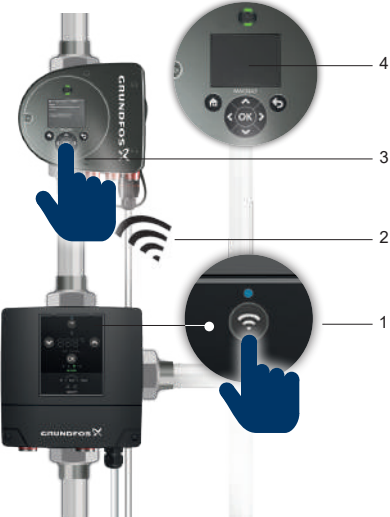
Step 1	Step 2
<p>Set AB port orientation</p> <p>Use the Up and Down buttons on the MIXIT operating panel to set the AB port flow orientation and press OK.</p>  <p style="text-align: right;">TM071477</p>	<p>Configure the pump</p> <p>Set the pump by completing the startup wizard.</p>  <p style="text-align: right;">TM071475</p>

Step 3	Step 4
<p>Connect the pump and the MIXIT unit</p> <p>By pressing the connectivity button on the MIXIT operating panel (1), MIXIT tries to establish contact with the pump (2). Confirm by pressing the OK button on the pump (3). The pump's display turns off after approximately 20 minutes (4).</p>  <p style="text-align: right;">TM071476</p>	<p>Set temperature setpoint</p> <p>Use the Up and Down buttons on the MIXIT operating panel to adjust the desired temperature setpoint. Press OK to complete the setup.</p>  <p style="text-align: right;">TM071478</p>

Shown with TPE3 pump

Step 1

Set AB port orientation

Use the **Up** and **Down** buttons on the MIXIT operating panel to set the AB port flow orientation and press **OK**.



TM080492

Step 2

Configure the pump

Set the pump by completing the startup wizard.



TM080493

Step 3

Connect the pump and the MIXIT unit

By pressing the connectivity button on the MIXIT operating panel (1), MIXIT tries to establish contact with the pump (2). Confirm by pressing the **OK** button on the pump (3). The pump's display turns off after approximately 20 minutes (4).



TM080494

Step 4

Set temperature setpoint

Use the **Up** and **Down** buttons on the MIXIT operating panel to adjust the desired temperature setpoint. Press **OK** to complete the setup.



TM080496



TM080495

For detailed instructions on setting up the product, see separate installation and operating instructions.

Related information

[Operating panel for MIXIT](#)

Temporary heating

In new buildings MIXIT can be used for dehumidification, as MIXIT is ready to operate after the initial startup of the system.

This means that you can dry out excess water content from building materials while construction work continues. When ready, any additional wiring and the remaining setup is completed via Grundfos GO Remote.

Setting up the product using Grundfos GO Remote

Once the initial start up of the MIXIT unit and pump is completed, MIXIT is connected with the Grundfos GO Remote app via Bluetooth.

Once connected, a wizard helps you set up your MIXIT system. The wizard lets you:

- turn on temporary heating
- define the application and circuit type
- choose whether MIXIT must operate as a two- or three-way valve
- set the pump's control mode, head and flow duty point
- define sensor inputs.

Once the setup wizard is completed, the functionalities available according to your chosen upgrade can be set. MIXIT can at all times be upgraded by downloading another upgrade via Grundfos GO Remote.

Monitoring MIXIT

Grundfos GO Remote allows you to monitor the system live, including:

- inputs from sensors
- mixed flow temperature and return temperature
- pump status
- valve status.

Fieldbus connection

If MIXIT is integrated into a building management system, the connectivity is configured via Grundfos GO Remote. When the fieldbus connection is established, the remaining configuration can be done via the bus system setup.

Fieldbus connection requires that the CONNECT upgrade has been activated.



TM071468

Connecting MIXIT with Grundfos GO Remote

Supply source set point

The supply source setpoint can be set using the Grundfos go remote after the initial start up of the MIXIT unit and pump is completed, MIXIT is connected with the Grundfos GO Remote app via Bluetooth..

Supply source setpoint can only be set using Grundfos go remote

For local supply source setpoint

Setting > Supply source setpoint > Supply source setpoint > Setpoint output type and Range

For daisy chain

Setting > Supply source setpoint > Daisy chain > Setpoint output type and Range

Related information

[System integration](#)

[Fieldbus integration](#)

Warnings and alarms

If MIXIT detects a warning or an alarm, it will be highlighted on its operating panel via the yellow (warning) and red (alarm) LED. See [8.1 Operating panel for MIXIT](#). The operating panel uses the LEDs of the temperature setpoint to show the error code.

The **Alarms and warnings** menu in Grundfos GO Remote describes the fault and lets you reset it when it has been corrected. This menu also keeps a log of previous warnings and alarms.

Firmware updates

MIXIT firmware is updated via Grundfos GO Remote.

If online and connected to MIXIT, the app automatically notifies the user about available updates. To update the firmware, simply follow the instructions in Grundfos GO Remote.

9. Operating conditions

Location

The product is designed for indoor installation.

Always install the product in a dry environment where it will not be exposed to drops or splashes, for example water, from surrounding equipment or structures. As the product contains stainless-steel parts, it is important that it is not installed directly in environments, such as:

- Indoor swimming pools where the product would be exposed to the ambient environment of the pool.
- Locations with direct and continuous exposure to a marine atmosphere.
- In rooms where hydrochloric acid (HCl) can form acidic aerosols escaping from, for example, open tanks or frequently opened or vented containers.

The above applications do not disqualify for installation of the product. However, it is important that the product is not installed directly in these environments.

Maximum distance between MIXIT and the pump

We recommend a maximum distance of 0.5 m between MIXIT and the pump to ensure optimal performance at low load.

Minimum space requirements

MIXIT requires the following space on the installation site.

	Clearance [mm]
Top and bottom	200
Left and right	100
Front and rear	100



TM075945

Ambient conditions

Ambient temperature during operation	0-50 °C
Ambient temperature during storage and transport	-40 to +70 °C
Relative humidity	Maximum 95 %

Maximum operating pressure

PN 6/10	6/10 bar / 0.6/1.0 MPa
PN 10	10 bar / 1.0 MPa

During normal operation, MIXIT must not be used at higher pressures than those indicated on the Valve nameplate.

Pumped liquids

The product is suitable for mixing clean, thin, non-aggressive and non-explosive liquids without solid particles or fibres.



The liquid must not be freezing or boiling.

The liquid temperature must be between 0 and 90 °C, not freezing or boiling. For short periods the temperature can be up to 110 °C provided that the media is being liquid and not boiling.

You can use the product for water, water-glycol-mixtures with up to 50 % glycol, or water-ethylene-mixtures with up to 50 % ethylene. No matter which is used, it is important that it is in a liquid state. Freezing or boiling of the media must be prevented.

For the flow measurement to function effectively and precisely at all flows, the viscosity must be equal to or below 2 cSt.

In heating systems, the water must meet the requirements of the accepted standard on water quality in heating systems according to local regulations.

The product is not intended for drinking water.

Radio communication

The radios of this product are placed in unlicensed bands and can be used without restrictions anywhere in the EU member states.

The MIXIT unit has two radio signals; GLoWPAN and Bluetooth.

The Grundfos proprietary wireless signal GLoWPAN is used for communication between MIXIT and the pump, while the Bluetooth Low Energy (BLE) radio is used for communication between MIXIT and Grundfos GO Remote.

10. Technical data

Type key

Example: MIXIT DYNAMIC 32 16 L NRV

Code	Designation	Explanation
MIXIT	Type range	MIXIT valve unit variant
[] DYNAMIC	Valve unit variant	[] : Standard functionalities included DYNAMIC: Standard and DYNAMIC upgrade functionalities included.
25 32 40 50	Nominal diameter (DN) of inlet and outlet ports [mm]	
6.3 10 16 25 40	K_{vs} value	
L R	B port orientation	L: Left R: Right
[] F	Pipe connection type	[] : Thread F: Flange
[] NRV	Hydraulic accessories	[] : No non-return valve NRV: Non-return valve

Cable requirements

Cable type: H05RN-F / H07RN-F

All control terminals are supplied by safety extra-low voltage (SELV) and separated.

All cables used must be heat-resistant up to at least 70 °C.

All cables used must be installed in accordance with EN 60204-1 and EN 50174-2:2000.

Use cable clamps and double insulated cables for relays.

Terminal	Cable	Cable cross section [mm ²]	Torque [Nm]
I/O terminals	Screened cable	0.5 - 1.5	0.2
AC supply	Cable	0.75 - 1.5	
RS-485	Screened 3-core cable		0.5
Relay 1 and 2	Screened cable	0.5 - 2.5	

Cable length

Speed [Mbit/s]	Cable type	Max. cable length [m/ft]
10	CAT5	100/328
100	CAT5e	100/328

Electrical data

All specified voltages refer to GND. GND is internally connected to protective earth.

Supply voltage	1 x 230 V ± 10 %, 50 Hz, PE
Protective class	I
Maximum power	15 W

Minimum power	2.5 W
Nominal power	8 W
Rated impulse-withstand voltage	4kV
Short-circuit current rating	500 A
Overvoltage category (OVC)	III
Pollution degree	2

Inputs and outputs

Absolute maximum voltage and current limits

Relay 1 and 2, maximum contact load	250 VAC or 30 VDC, 2 A
RS-485 terminal	-5.5 to +9.0 VDC, else < 25 mADC
Other I/O terminals	-0.5 to +26 VDC, else < 15 mADC

Exceeding the electrical limits may result in severely reduced operating reliability and product life.

Digital input (DI)

Internal pull-up current	> 10 mA at $V_i = 0$ V, $R_i = 100$ k Ω at $V_i > 5$ V
Certain low logic level	$V_i < 1.8$ V
Certain high logic level	$V_i > 2.7$ V or floating
Hysteresis	Yes

The I/Os, CIO and DI, are 24 V tolerant.

Relay outputs

Potential-free changeover contacts (SPDT)	
Contact ratings	250 VAC, 2 A, 50/60 Hz, AC-1 (resistive)
Action type	1.B (micro disconnection)
Minimum contact load when in use	5 VDC, 10 mA

Analog input (AI)

Voltage mode range	0-10 V
Voltage mode	$R_i = 100$ k Ω
Current mode range	4-20 mA
Current mode	V_{in} (appr.) = $\ln * 50 \Omega + 1$ V
Current mode overload protection	Yes, current limit > 75 mA
Measurement tolerance	± 3 % of full scale

Analog output (AO)

Sourcing capability only	
Voltage mode range	0-10 V
Min. load between AO and GND	3 k Ω
Short-circuit protection	Yes
Current mode range	4-20 mA
Voltage drive capability	10 V at 20 mA
Open-circuit protection	Yes
Tolerance	± 5 % of set value

Pt1000 input (PT)

Temperature measurement range	-30 to +180 °C
Measurement tolerance	± 1.5 °C
Measurement resolution	0.15 °C

Power supplies (24 V)

Output voltage	-24 VDC \pm 5 %
Max. current	100 mA DC (sourcing only)
Overload protection	Yes

Bus input (RS-485)

Protocols	GENIbus, BACnet MS/TP, Modbus RTU, RS-485
Supply voltage	5 VDC \pm 5 %, I_{max} . 350mA

Bus input (Ethernet)

Protocols	BACnet IP, Modbus TCP
Cable type, BACnet IP	Standard CAT5, CAT5e or CAT6
Cable type, Modbus TCP	Standard CAT5, CAT5e or CAT6

Classes

Temperature class	TF110 (EN 60335-2-51)
Enclosure class	X4D (EN 60529)

Sound pressure level

The sound pressure level for MIXIT without cavitation is below 40 dB(A) (pressure differential across the valve A - AB <100kPa).

Actuator

Ball valve, movement and type of action	Angular rotation, 360 ° both ways Multi-position
Temperature for ball pressure test	125 °C
Maximum rated mechanical load	15 Nm
Travel time	1 minute (90 ° / 15 seconds)
Limitation of operating time	1 second on / 4 seconds off

Sensor data

Vortex flow sensor, port A	From 0.3 m ³ /h depending on the MIXIT variant with a dynamic range of 1:25.
Temperature range, port A and port B	-10 to +120 °C
Accuracy temperature, port A and port B	± 1.25 °C (-10 to +80 °C), ± 1.3 °C (80-90 °C), ± 2 °C (90-110 °C) Flow ratio, Q _{ab} /Q _a : 1.1 - 10.

Flow sensor accuracy

The curves show how accurate the flow sensor measures the actual flow.

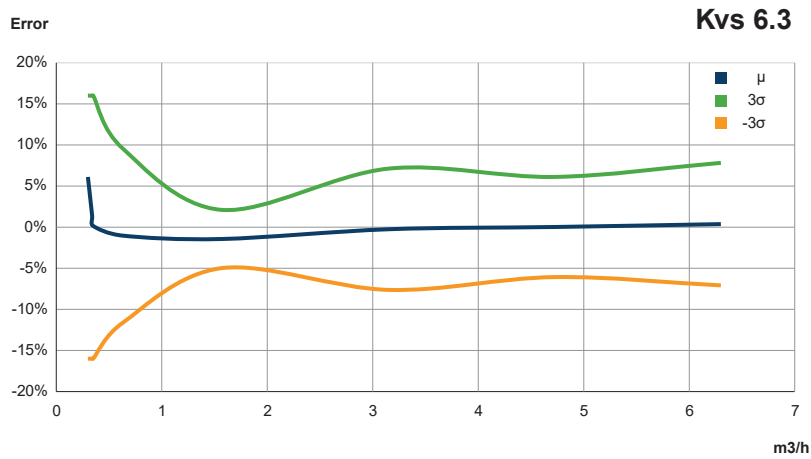

TM074191

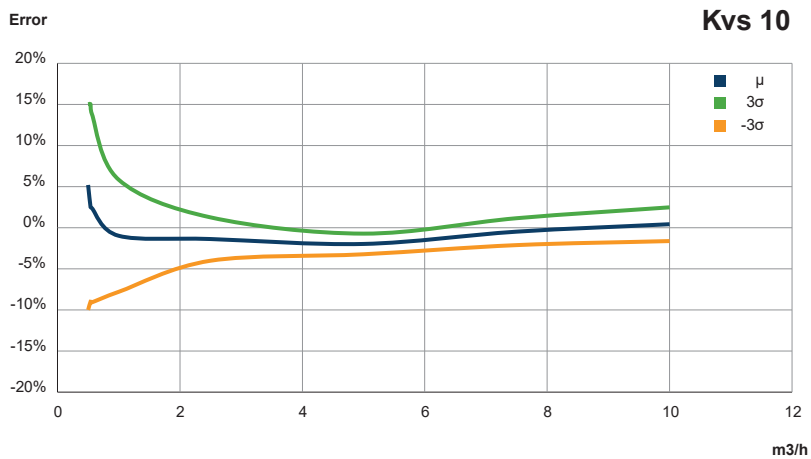

TM074192

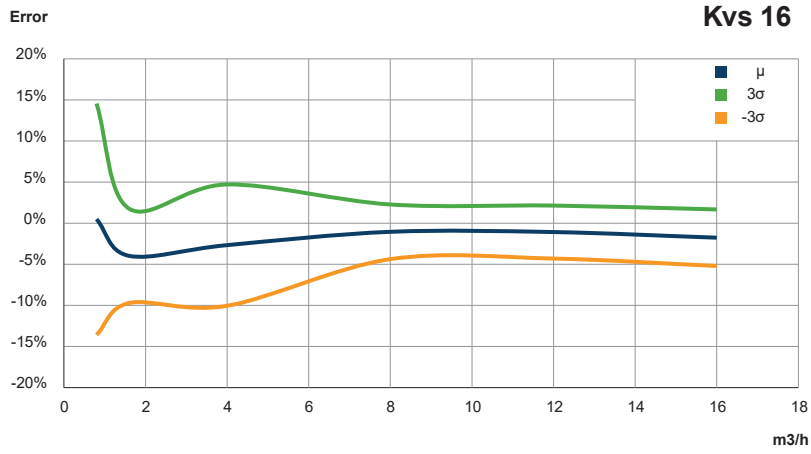

TM074193

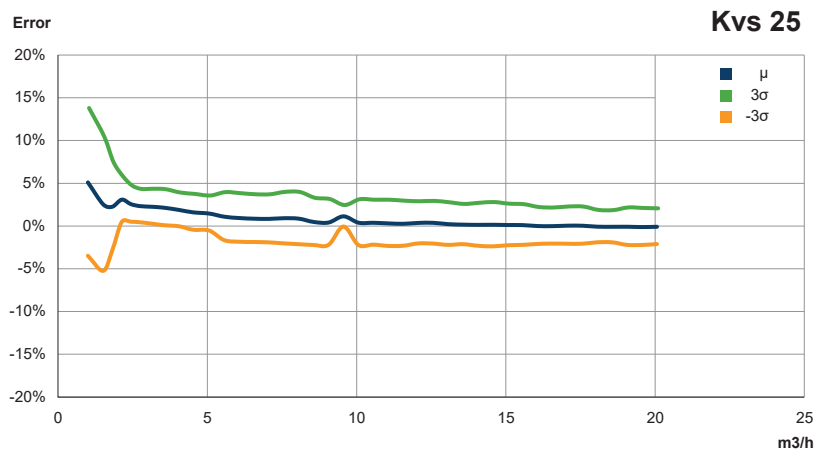

TM084341

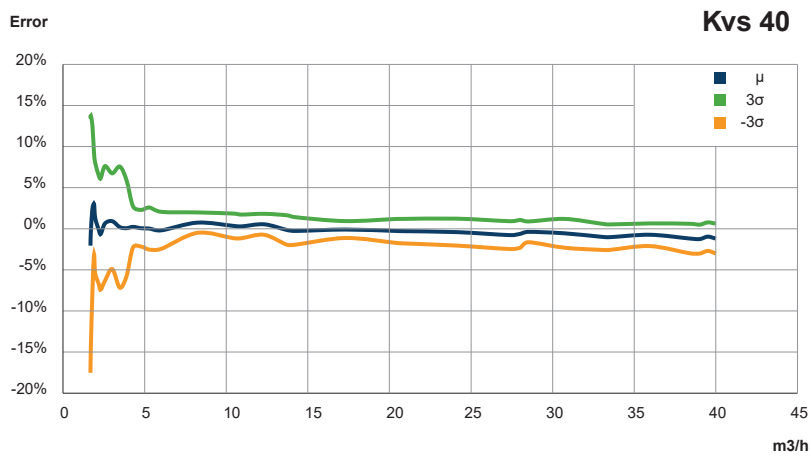

TM081910

Valve

Valve details

Type of valve	Mixing valve
Function	Three-way inverting valve or two-way modulating valve with integrated shunt
Type of closure member	Ball
Type of operation	Directly controlled and operated, no minimum differential pressure
Type of movement	Rotational, no mechanical stops
Positioning	Modulating
Valve stroke (rated travel)	90 °
Position when de-energised	N/A, no fail-safe
Leakage	Port A: max. $5 \cdot 10^{-6} \cdot K_{vs}$ (according to EN 60534-4, class IV-S1) Port B: max. $10^{-3} \cdot K_{vs}$ (according to EN 60534-4, class III)

Connections (Threaded version)

Number of ports	3
Type of end-connection	Externally threaded, ISO 228-1
Inner dimension of ports	DN size
Dimension of end-connection threads	DN 25 - G 1 1/2, DN 32 - G 2

Connections (Flanged version)

Number of ports	3
Type of end-connection	Flange connection, EN 1092-2
Inner dimension of ports	DN size
Dimension of end - pipe connection	DN 32, DN 40, DN 50

Size and capacity

DN size	Capacity [K_{vs}]
DN 25-6.3	6.3
DN 25-10	10
DN 32-16	16
DN 40-25	25
DN 50-40	40

Media and working conditions

Minimum temperature	0 °C, non-freezing
Maximum temperature	90 °C
Maximum temperature, short term	110 °C, non-boiling
Minimum differential pressure	0 bar
Maximum differential pressure for normal operation and close-off	2.5 bar
Maximum differential pressure for positioning	5 bar
Maximum differential pressure, not for normal operation	10 bar
Maximum rated working pressure (PS)	10 bar
Liquid types	Water Water-glycol-mixtures with up to 50 % glycol Water-ethylene-mixtures with up to 50 % ethylene
Not suitable for drinking water.	

Wetted materials

Valve housing	Cast iron GJS500-7, CED coated
O-rings	EPDM (EP70)
Seats	Carbon reinforced PTFE
Ball	Brass CW614N, Ni and Cr plated
Other metal parts	Stainless steel
Friction discs	PTFE

Other plastic parts	PPS 40-GF
Non-return valve (Threaded versions only)	PPO, EPDM, stainless steel
Sensors	PPS, EPDM, corrosion-resistant coating

Cavitation risk

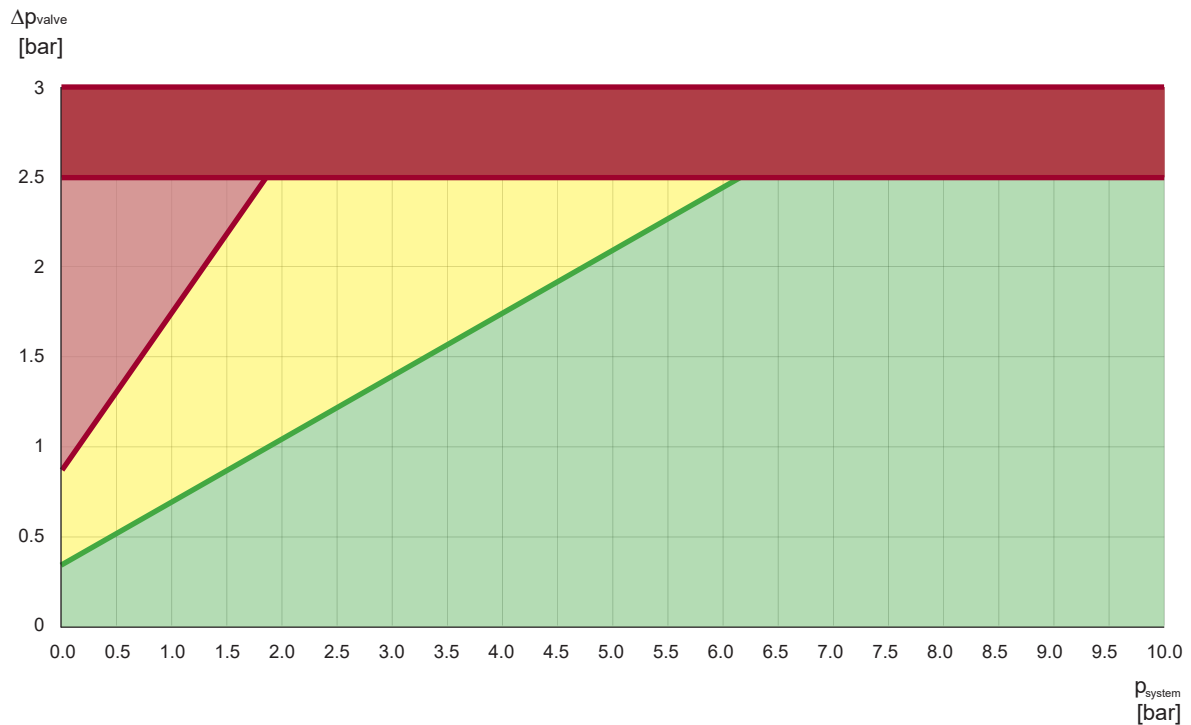

TM073275

Cavitation risk in a system with a liquid temperature of 20 °C. Y axis: Differential pressure [bar]. X axis: Static pressure, relative [bar].

Coloured area	Description
Green	No or very low risk of cavitation
Yellow	Risk of cavitation
Light red	Cavitation
Dark red	The differential pressure must not exceed 2.5 bar.

As a rule of thumb, the relative static pressure must be at least 3 times the differential pressure across any valve in the system. According to the figure above, cavitation is present in the light red area, while the dark red area is out of specification. Stay clear of the red areas and carefully consider avoiding the yellow area. The risk of cavitation increases with the temperature, and thus the static pressure must be adjusted accordingly.

Valve characteristics

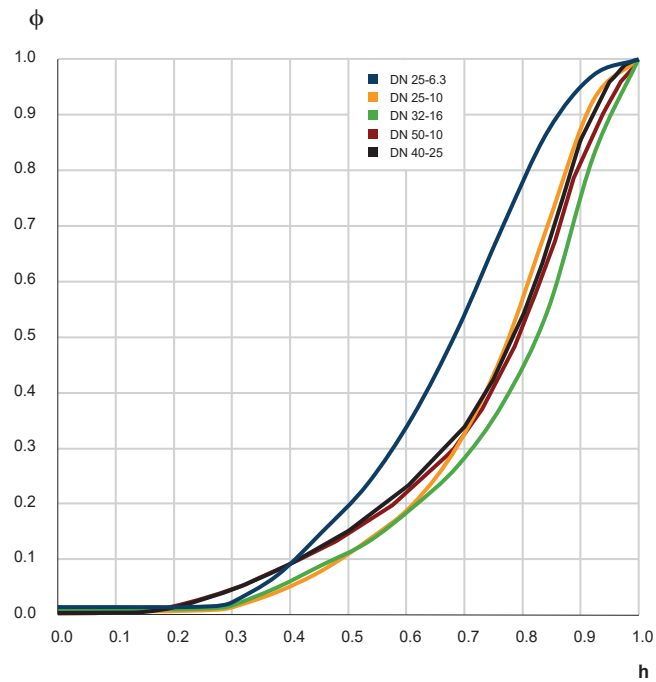

TM077383

Inherent flow characteristic for A-AB in modified equal percentage. X axis: Relative travel, h . Y axis: Relative flow coefficient, Φ .

Inherent flow characteristic A-AB	Modified equal percentage (tested according to EN 60534-2-4 and VDI/VDE 2173)
Inherent flow characteristic B-AB, three-way function	Modified equal percentage (tested according to EN 60534-2-4 and VDI/VDE 2173)
Inherent flow characteristic B-AB, two-way function	Fully open
Inherent rangeability A-AB	>150 (tested according to EN 60534-2-4 and VDI/VDE 2173)

11. Dimensions

Threaded version

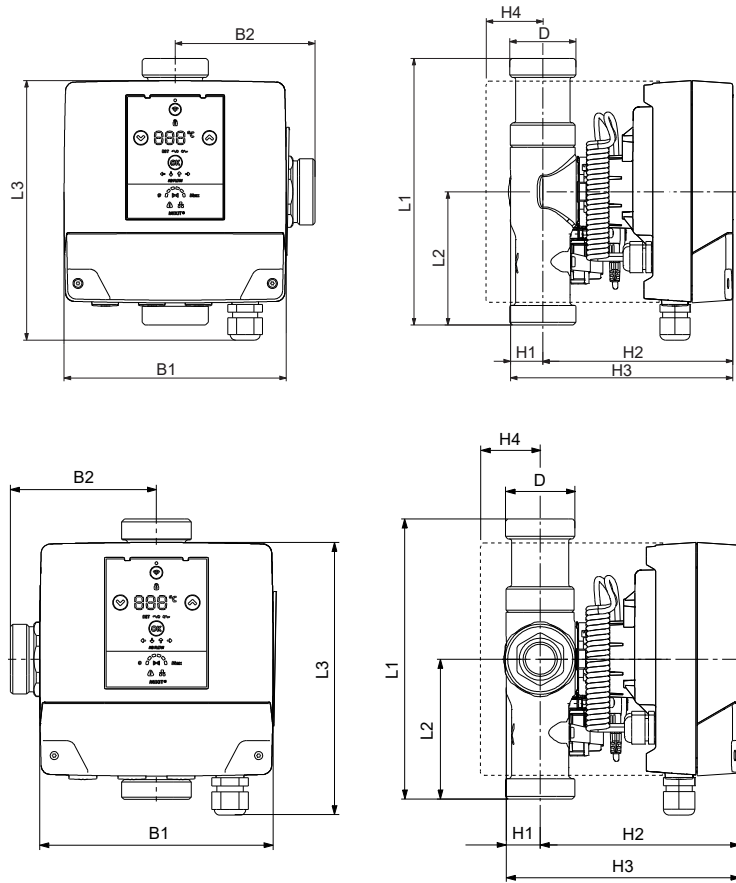

TM073144

TM080464

Dimensions [mm]

MIXIT type	D [inch]	L1	L2	L3	B1	B2	H1	H2	H3	H4	Net weight [kg]	Gross weights [kg]	Ship. vol. [m ³]
25-6.3 L NRV	G 1 1/2	240	120	233	200	125	26	168	194	60	5.6	6.8	0.032
25-6.3 R NRV	G 1 1/2	240	120	233	200	125	26	168	194	60	5.6	6.8	0.032
25-10 L NRV	G 1 1/2	240	120	233	200	125	26	168	194	60	5.6	6.8	0.032
25-10 R NRV	G 1 1/2	240	120	233	200	125	26	168	194	60	5.6	6.8	0.032
32-16 L NRV	G 2	240	120	233	200	125	29	171	200	57	6.2	7.4	0.032
32-16 R NRV	G 2	240	120	233	200	125	29	171	200	57	6.2	7.4	0.032

Flange version

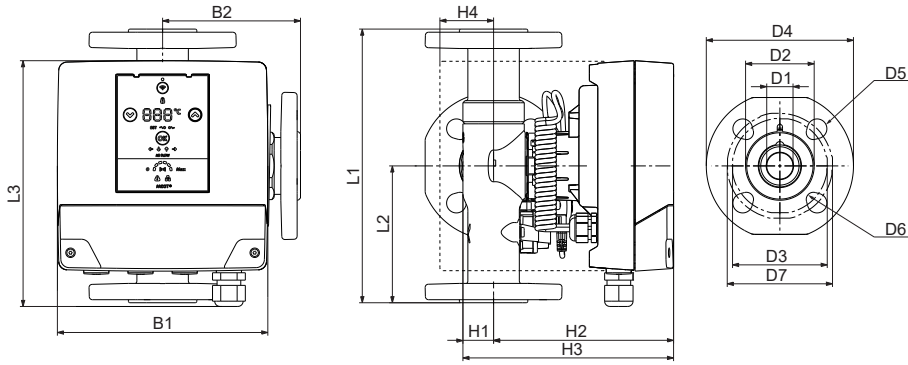

TM073161

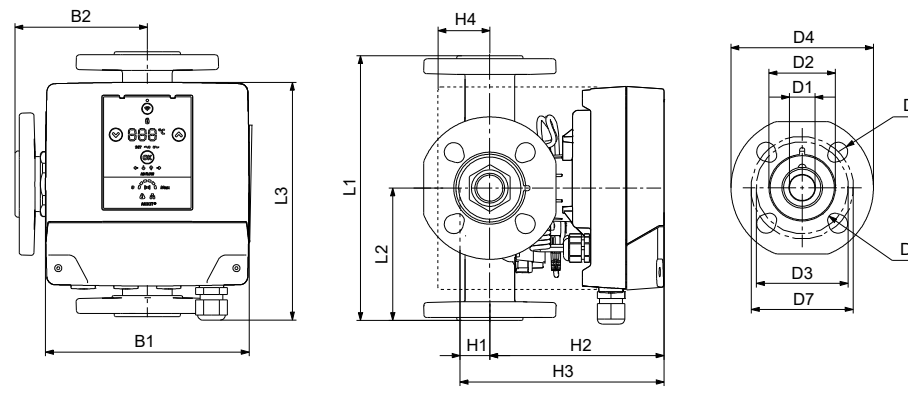

TM080442

Dimensions [mm]

MIXIT type	L1	L2	L3	B1	B2	H1	H2	H3	H4	D1	D2	D3	D4	D5	D6	D7	Net weight [kg]	Gross weights [kg]	Ship. vol. [m ³]
32-16 L F	270	135	233	200	135	29	171	200	65	25	65	90	140	19	14	100	14.5	15.5	0.032
32-16 R F	270	135	233	200	135	29	171	200	65	25	65	90	140	19	14	100	14.5	15.5	0.032

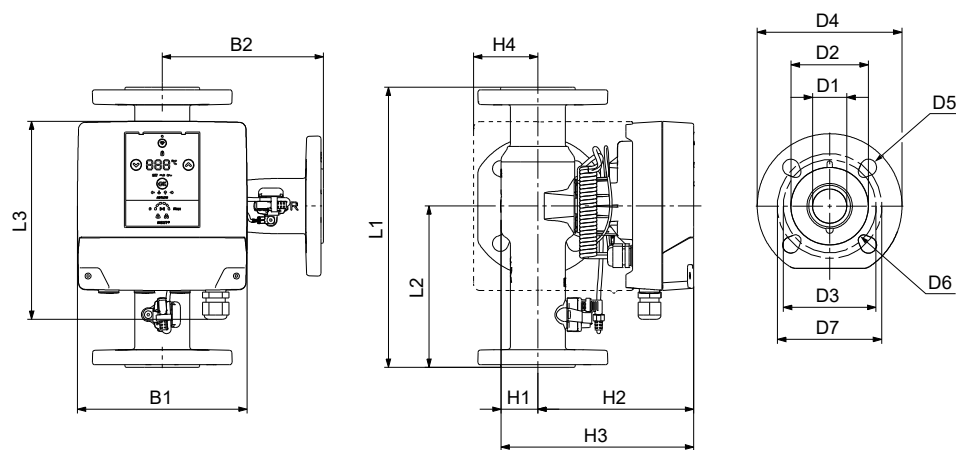

TM080051

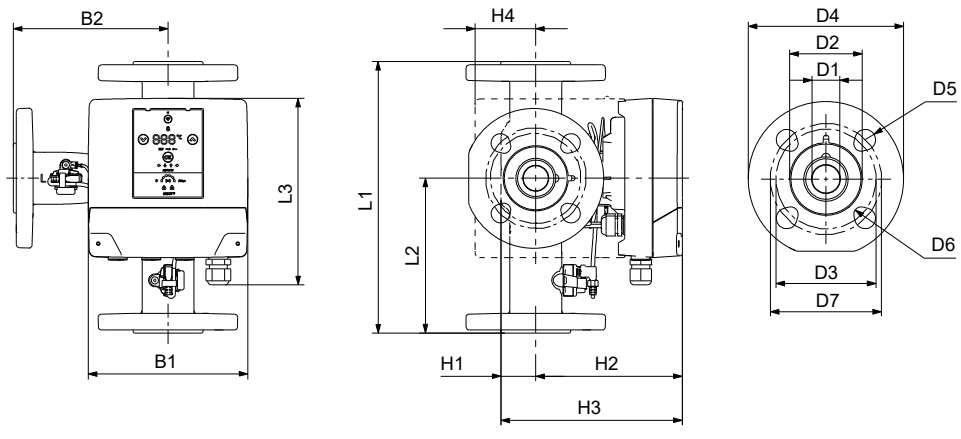

TM080689

Dimensions [mm]

MIXIT type	L1	L2	L3	B1	B2	H1	H2	H3	H4	D1	D2	D3	D4	D5	D6	D7	Net weight [kg]	Gross weights [kg]	Ship. vol. [m ³]
40-25 L F	330	190	233	200	190	36	176	212	70	32	78	100	150	18	12	110	17.8	18.8	0.050
40-25 R F	330	190	233	200	190	36	176	212	70	32	78	100	150	18	12	110	17.8	18.8	0.050
50-40 L F	330	190	233	200	190	43	184	227	76	40	88	110	165	19	13	125	21.5	22.5	0.050
50-40 R F	330	190	233	200	190	43	184	227	76	40	88	110	165	19	13	125	21.5	22.5	0.050

12. Accessories

Insulating shells for heating systems

Insulating shells for heating systems are supplied with the product, but can also be ordered as an accessory.

Insulating shells for airconditioning and cooling systems can also be ordered as an accessory.

Insulating shells	Product number
DN 25 thread	99566203
DN 32 thread	99566205
DN 32 flange	99566207
DN 40 flange	99566208
DN50 flange	99566210

Non-return valve

Threaded versions of MIXIT, DN 25-32, are fitted with a non-return valve from factory. For flange versions, DN 32-50, non-return valves are available as accessories and are mounted externally at the B-port of the valve.

For flange versions, DN32-50, non-return valves are fitted externally at the B-port on the valve. The non-return valve have to fit the actually DN size.

Non-return valve for flange versions	Product number
DN 32	
DN 40	
DN 50	

Outdoor temperature sensors

An outdoor temperature sensor can be fitted to make use of the **Weather curve** and **Warm-weather shutdown** functionalities, in which MIXIT automatically adjusts the mixed flow temperature to the actual temperature outside. The ESMT sensor is used for single MIXIT systems, while the DOL 114 RH/T sensor is suitable if the signal is to be shared between several MIXIT units.



TM072916

Left to right: ESMT and DOL 114 RH/T sensor

Sensor	Type	Supplier	Measuring range [°C]	Output signal	Product number
Outdoor temperature sensor	ESMT	Danfoss	-30 °C to 50 °C	Pt1000	99113175
Outdoor temperature sensor	DOL 114 RH/T	Dol Sensors	-40 °C to 60 °C	0 - 10 V	99113183

Radiation shield

A radiation shield is available for the DOL 114 sensor. The shield protects the sensor from rain and radiated heat.

Product	Supplier	Product number
Radiation shield for DOL 114	Dol Sensors	99113181

Temperature sensors



TM072917

ESM-11 sensor

Sensor	Type	Supplier	Measuring range [°C]	Output signal	Product number
Temperature sensor, outside pipe	ESM-11	Danfoss	0 °C to 100 °C	Pt1000	99113176



TM086654

Jumo, Type: 902520

Sensor	Type	Supplier	Measuring range [°C]	Output signal	Product number
Outdoor temperature sensor	902520	Jumo	-40 °C to 60 °C	0 - 10 V	93099391

Temperature protection switch

To provide a thermal protection in the system, a temperature protection switch can be installed. Once the temperature of 50 °C is reached, the temperature switch activates the input terminal of the MIXIT unit causing the valve to close.

Product	Supplier	Switching temperature	Product number
Temperature switch	JUMO	50 °C	99113180

Thread-thread adapters

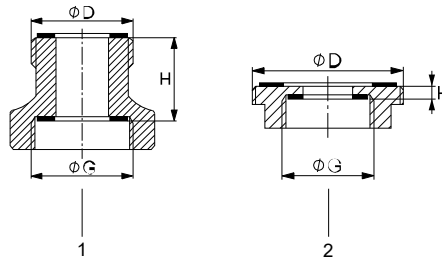

TM072904

New connection G	Union nut connection D	Adapter length [mm] H	Adapter type	Pos.	Material	Product number
G 1 1/2	G 1 1/2	1 x 70	A 4	1	Cast iron (GG)	535043
G 1 1/2	G 1 1/2	1 x 25	A 5	1	Cast iron (GG)	535044
G 1 1/2	G 2	2 x 0	A 6	2	Brass (Ms)	535045
G 1 1/2	G 2	2 x 5	A 7	2	Bronze (Rg)	535046
G 1 1/2	G 2	2 x 35	A 8	1	Cast iron (GG)	535047
G 2	G 2	1 x 20	A 9	1	Bronze (Rg)	535048
G 2	G 2	1 x 26	A 10	1	Cast iron (GG)	535049
G 2	G 2	1 x 70	A 11	1	Cast iron (GG)	535050

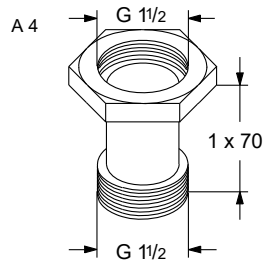

TM072957

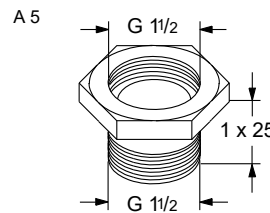

TM072958

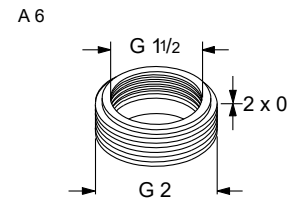

TM072959

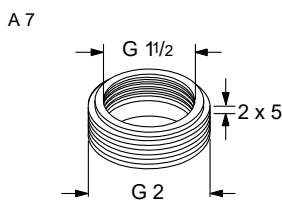

TM072960

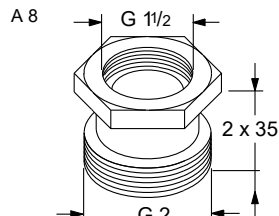

TM072961

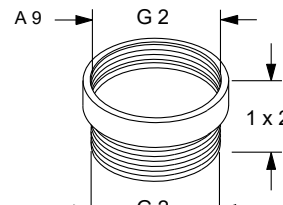

TM072962

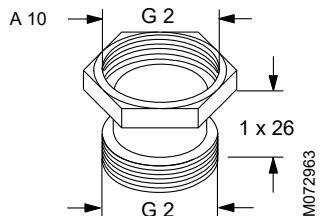

TM072963

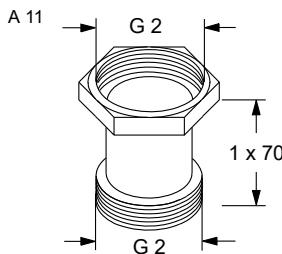

TM072964

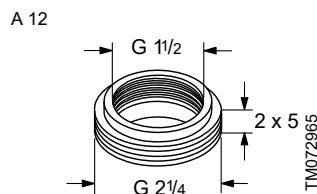

TM072965

Thread types

G-threads have a cylindrical form in accordance with EN-ISO 228-1 standard.

R-threads have a conical form in accordance with ISO 7-1 standard.

In case the thread size is, for example, 1 1/2", the threads are specified as G 1 1/2 or R 1 1/2. Male G-threads (cylindrical) can only be screwed into female G-threads. Male R-threads (conical) can be screwed into female G or R-threads.

Thread-flange adapters

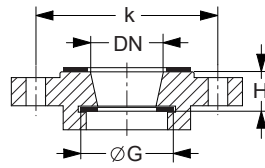

TM060450

New connection G	Flange connection DN	Adapter length H [mm]	k [mm]	Adapter type	Material	Product number PN 6	Product number PN 10
G 1 1/2	DN 32	2 x 20	90	A 14	Cast iron (GG)	535053	
G 1 1/2	DN 40	2 x 20	100	A 17	Cast iron (GG)	535056	
G 1 1/2	DN 50	1 x 20	110	A 19	Cast iron (GG)	535058	
G 2	DN 32	2 x 20	90	A 15	Cast iron (GG)	535054	
G 2	DN 40	2 x 20	100	A 18	Cast iron (GG)	98614387	
G 2	DN 50	2 x 20	110	A 20	Cast iron (GG)	98614411	

A 14

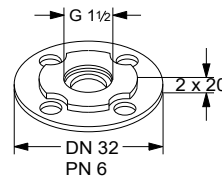

TM072970

A 15

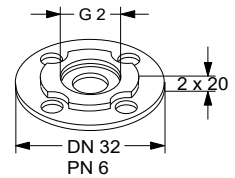

TM072971

A 17

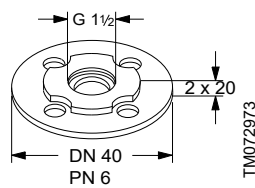

TM072973

A 18

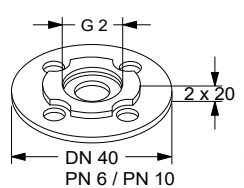

TM072974

A 19

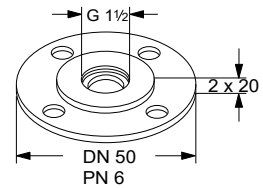

TM072975

A 20

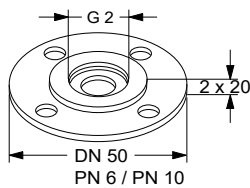

TM072976

A 22

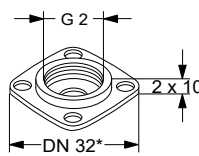

TM072977

A 28

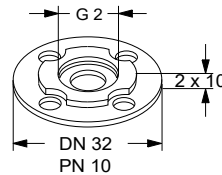

TM072978

Flange-flange adapters

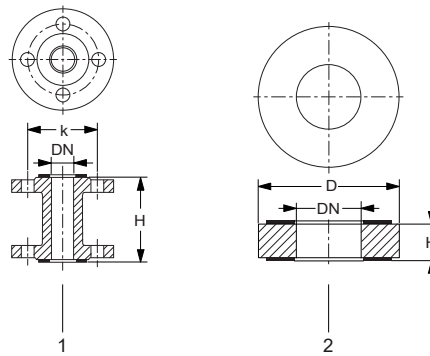

TM072905

New connection DN	Adapter length H [mm]	k		D		Adapter type	Pos.	Material	Product number PN 6	Product number PN 10
		[mm] PN 6	[mm] PN 10	[mm] PN 6	[mm] PN 10					
DN 40	1 x 70	100	110			A 40-70	2	Cast iron (GG)	539921	539721
DN 40	1 x 30			82	88	A 40-30	1	Steel	96281076	96608515
DN 50	1 x 10			90	102	A 50-10	1	Cast iron (GG)	549921	549821
DN 50	1 x 20			90	102	A 50-20	1	Cast iron (GG)	549922	549822
DN 50	1 x 40			90	102	A 50-40	1	Steel	96281077	96608516
DN 50	1 x 50			90	102	A 50-50	1	Cast iron (GG)	549923	549823
DN 50	1 x 60	110	125			A 50-60	2	Cast iron (GG)	549924	549824
DN 65	1 x 10			110	122	A 65-10	1	Cast iron (GG)	559921	559821
DN 65	1 x 25			110	122	A 65-25	1	Cast iron (GG)	559922	559822
DN 65	1 x 160	130	145			A 65-160	2	Steel (St)	559923	559823

A 40-30

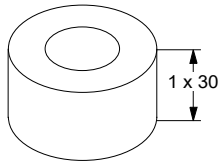

TM072979

A 40-70

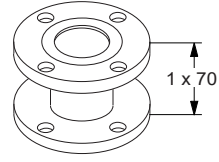

TM072980

A 50-10

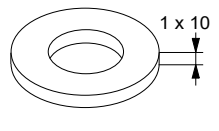

TM072981

A 50-20

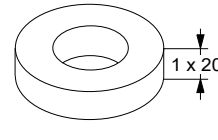

TM072982

A 50-40

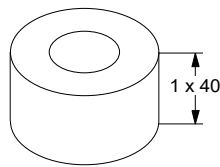

TM072983

A 50-50

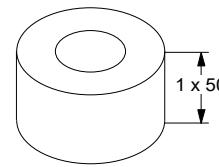

TM072984

A 50-60

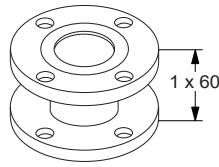

TM072985

A 65-10

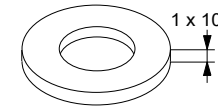

TM072986

A 65-25

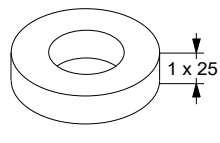

TM072987

A 65-160

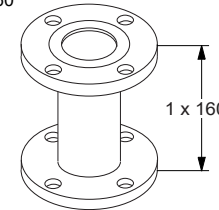

TM072988

■ DN 50/40 flange adapters

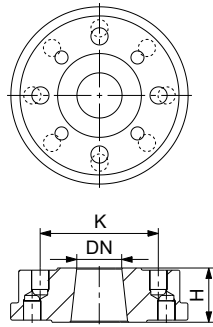

TM080592

New connection DN	Adapter length H [mm]	k [mm] PN 6	k [mm] PN 10	Adapter type	Material	Product number PN 6 / PN 10
DN 50/40	1 x 50.5	100	110	A 50-40	Steel	92601639

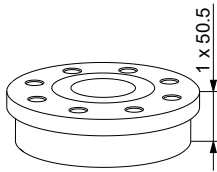

TM080591

■ DN 65/50 flange adapters

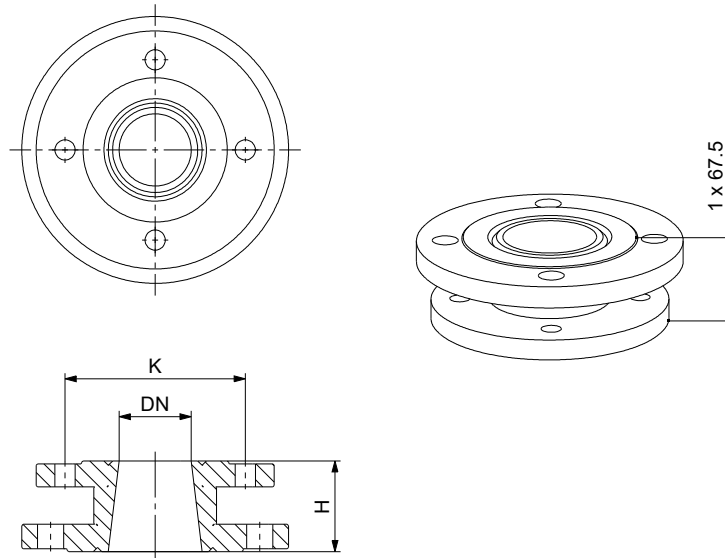

TM081935

New connection DN	Adapter length H [mm]	k [mm]	Adapter type	Material	Product number PN 10
DN 65/50	1 x 65.5	125	A 65-50	Steel	96497649

13. Product numbers

When ordering a complete MIXIT system, you are required to choose:

- A MIXIT valve unit, either the MIXIT or MIXIT DYNAMIC variant
- A MAGNA3 pump
The MIXIT valve units are applicable with the MAGNA3 pumps as stated in the table in [2. Performance range](#).
- A TPE3 pump
The MIXIT valve units are applicable with the TPE33 pumps as stated in the table in [2. Performance range](#).
- Optional: A DYNAMIC or CONNECT upgrade when wanting to acquire more functionalities.

Related information

[2. Performance range](#)

MIXIT valve unit

Valve unit	Product number	
	PN 10	PN 6/10
MIXIT 25-6.3 L NRV	99508816	
MIXIT 25-6.3 R NRV	99508818	
MIXIT 25-10 L NRV	99508819	
MIXIT 25-10 R NRV	99508820	
MIXIT 32-16 L NRV	99508822	
MIXIT 32-16 R NRV	99508834	
MIXIT 32-16 L F		99508836
MIXIT 32-16 R F		99508837
MIXIT 40-25 L F		99508838
MIXIT 40-25 R F		99508839
MIXIT 50-40 L F		99508840
MIXIT 50-40 R F		99508841
MIXIT DYNAMIC 25-6.3 L NRV	99524563	
MIXIT DYNAMIC 25-6.3 R NRV	99524667	
MIXIT DYNAMIC 25-10 L NRV	99524668	
MIXIT DYNAMIC 25-10 R NRV	99524669	
MIXIT DYNAMIC 32-16 L NRV	99524670	
MIXIT DYNAMIC 32-16 R NRV	99524671	
MIXIT DYNAMIC 32-16 L F		99524683
MIXIT DYNAMIC 32-16 R F		99524684
MIXIT DYNAMIC 40-25 L F		99524685
MIXIT DYNAMIC 40-25 R F		99524686
MIXIT DYNAMIC 50-40 L F		99524687
MIXIT DYNAMIC 50-40 R F		99524688

Abbreviations:

L: Left variant.

R: Right variant.

NRV: Non-return valve included.

DYNAMIC: The DYNAMIC upgrade is installed from factory.

F: Flange version.

Upgrades

Upgrade	Product number
DYNAMIC, 1 licence (box)	99558420
DYNAMIC, 1 licence (digital)	99725067
DYNAMIC, 5 licences (digital)	99725068
CONNECT, 1 licence (box)	99558443
CONNECT, 1 licence (digital)	99725069
CONNECT, 5 licences (digital)	99725070

MAGNA3 single-head pumps

Pump type	Product number	
	PN 10	PN 6/10
MAGNA3 25-40	97924244	
MAGNA3 25-60	97924245	
MAGNA3 25-80	97924246	
MAGNA3 25-100	97924247	
MAGNA3 25-120	97924248	
MAGNA3 32-40	97924254	
MAGNA3 32-60	97924255	
MAGNA3 32-80	97924256	
MAGNA3 32-100	97924257	
MAGNA3 32-120	98609707	
MAGNA3 32-40 F		98333834
MAGNA3 32-60 F		98333854
MAGNA3 32-80 F		98333874
MAGNA3 32-100 F		97924258
MAGNA3 32-120 F		97924259
MAGNA3 40-40 F		97924266
MAGNA3 40-60 F		97924267
MAGNA3 40-80 F		97924268
MAGNA3 40-100 F		97924269
MAGNA3 40-120 F		97924270
MAGNA3 40-150 F		97924271
MAGNA3 40-180 F		97924272
MAGNA3 50-40 F		97924280
MAGNA3 50-60 F		97924281
MAGNA3 50-80 F		97924282
MAGNA3 50-100 F		97924283
MAGNA3 50-120 F		97924284
MAGNA3 50-150 F		97924285
MAGNA3 50-180 F		97924286
MAGNA3 65-40 F		97924294
MAGNA3 65-60 F		97924295
MAGNA3 65-80 F		97924296
MAGNA3 65-100 F		97924297
MAGNA3 65-120 F		97924298
MAGNA3 65-150 F		97924299

MAGNA3 twin-head pumps

Pump type	Product number	
	PN 10	PN 16
MAGNA3 D 32-40	97924449	97924455
MAGNA3 D 32-60	97924450	97924456
MAGNA3 D 32-80	97924451	97924457
MAGNA3 D 32-100	97924452	97924458

Pump type	Product number	
	PN 6/10	PN 16
MAGNA3 D 32-40 F	98333840	98333838
MAGNA3 D 32-60 F	98333860	98333858
MAGNA3 D 32-80 F	98333880	98333878
MAGNA3 D 32-100 F	97924453	97924459
MAGNA3 D 32-120 F	97924454	97924460
MAGNA3 D 40-40 F	97924461	97924468
MAGNA3 D 40-60 F	97924462	97924469
MAGNA3 D 40-80 F	97924463	97924470
MAGNA3 D 40-100 F	97924464	97924471
MAGNA3 D 40-120 F	97924465	97924472
MAGNA3 D 40-150 F	97924466	97924473
MAGNA3 D 40-180 F	97924467	97924474
MAGNA3 D 50-40 F	97924475	97924482
MAGNA3 D 50-60 F	97924476	97924483
MAGNA3 D 50-80 F	97924477	97924484
MAGNA3 D 50-100 F	97924478	97924485
MAGNA3 D 50-120 F	97924479	97924486
MAGNA3 D 50-150 F	97924480	97924487
MAGNA3 D 50-180 F	97924481	97924488
MAGNA3 D 65-40 F	97924489	97924495
MAGNA3 D 65-60 F	97924490	97924496
MAGNA3 D 65-80 F	97924491	97924497
MAGNA3 D 65-100 F	97924492	97924498
MAGNA3 D 65-120 F	97924493	97924499
MAGNA3 D 65-150 F	97924494	97924500

MAGNA3 single-head pumps for the German market

Pump type	Product number	
	PN 10	PN 6/10
MAGNA3 25-40	97924623	
MAGNA3 25-60	97924624	
MAGNA3 25-80	97924625	
MAGNA3 25-100	97924626	
MAGNA3 25-120	97924627	
MAGNA3 32-40	97924633	
MAGNA3 32-60	97924634	
MAGNA3 32-80	97924635	
MAGNA3 32-100	97924636	
MAGNA3 32-120	98609708	
MAGNA3 32-40 F		98333835
MAGNA3 32-60 F		98333855
MAGNA3 32-80 F		98333875
MAGNA3 32-100 F		97924637
MAGNA3 32-120 F		97924638
MAGNA3 40-40 F		97924645
MAGNA3 40-60 F		97924646
MAGNA3 40-80 F		97924647
MAGNA3 40-100 F		97924648
MAGNA3 40-120 F		97924649
MAGNA3 40-150 F		97924650
MAGNA3 40-180 F		97924651
MAGNA3 50-40 F		97924659
MAGNA3 50-60 F		97924660
MAGNA3 50-80 F		97924661
MAGNA3 50-100 F		97924662
MAGNA3 50-120 F		97924663
MAGNA3 50-150 F		97924664
MAGNA3 50-180 F		97924665
MAGNA3 65-40 F		97924674
MAGNA3 65-60 F		97924675
MAGNA3 65-80 F		97924676
MAGNA3 65-100 F		97924677
MAGNA3 65-120 F		97924678
MAGNA3 65-150 F		97924679

MAGNA3 twin-head pumps for the German market

Pump type	Product number	
	PN 10	PN 16
MAGNA3 D 32-40	97924829	97924835
MAGNA3 D 32-60	97924830	97924836
MAGNA3 D 32-80	97924831	97924837
MAGNA3 D 32-100	97924832	97924838

Pump type	Product number	
	PN 6/10	PN 16
MAGNA3 D 32-40 F	98333841	98333839
MAGNA3 D 32-60 F	98333861	98333859
MAGNA3 D 32-80 F	98333881	98333879
MAGNA3 D 32-100 F	97924833	97924839
MAGNA3 D 32-120 F	97924834	97924840
MAGNA3 D 40-40 F	97924841	97924848
MAGNA3 D 40-60 F	97924842	97924849
MAGNA3 D 40-80 F	97924843	97924850
MAGNA3 D 40-100 F	97924844	97924851
MAGNA3 D 40-120 F	97924845	97924852
MAGNA3 D 40-150 F	97924846	97924853
MAGNA3 D 40-180 F	97924847	97924854
MAGNA3 D 50-40 F	97924855	97924862
MAGNA3 D 50-60 F	97924856	97924863
MAGNA3 D 50-80 F	97924857	97924864
MAGNA3 D 50-100 F	97924858	97924865
MAGNA3 D 50-120 F	97924859	97924866
MAGNA3 D 50-150 F	97924860	97924867
MAGNA3 D 50-180 F	97924861	97924868
MAGNA3 D 65-40 F	97924869	97924875
MAGNA3 D 65-60 F	97924870	97924876
MAGNA3 D 65-80 F	97924871	97924877
MAGNA3 D 65-100 F	97924872	97924878
MAGNA3 D 65-120 F	97924873	97924879
MAGNA3 D 65-150 F	97924874	97924880

TPE3 single-head pumps

Pump type
TPE3 32-80
TPE3 32-120
TPE3 32-150
TPE3 32-180
TPE3 32-200
TPE3 40-80
TPE3 40-120
TPE3 40-150
TPE3 40-180
TPE3 40-200
TPE3 40-240
TPE3 50-60
TPE3 50-80
TPE3 50-120
TPE3 50-150
TPE3 50-180
TPE3 50-200
TPE3 50-240
TPE3 65-60
TPE3 65-80
TPE3 65-120
TPE3 65-150
TPE3 65-180
TPE3 65-200

The product numbers for TPE3 pumps are found in Grundfos product center See [Grundfos Product Center](#)

TPE3 twin-head pumps

Pump type
TPE3 D 32-80
TPE3 D 32-120
TPE3 D 32-150
TPE3 D 32-180
TPE3 D 32-200
TPE3 D 40-80
TPE3 D 40-120
TPE3 D 40-150
TPE3 D 40-180
TPE3 D 40-200
TPE3 D 40-240
TPE3 D 50-60
TPE3 D 50-80
TPE3 D 50-120
TPE3 D 50-150
TPE3 D 50-180
TPE3 D 50-200
TPE3 D 50-240
TPE3 65-60
TPE3 65-80
TPE3 65-120
TPE3 65-150
TPE3 65-180
TPE3 65-200

The product numbers for TPE3 pumps are found in Grundfos product center See [Grundfos Product Center](#)

14. Technical terms

Actuator	An actuator controls the opening of a valve via a control signal. MIXIT has a built in actuator in its control box.
A port	Port on the MIXIT unit.
AB port	Port on the MIXIT unit. The mixed liquid from the A and B port is led out through the AB port.
BACnet	BACnet is a communications protocol for building, automation and controls network. The protocol governs how devices across building automation systems work together.
Ball valve	A hollow ball, which is used to control the flow through it. The ball valve in MIXIT can be configured both as a two-way valve and a three-way valve. MIXIT changes between the two simply by changing the opening direction of the ball valve.
Bluff body	When a bluff body is placed inside a pipe, a series of vortices will be generated on either side of the bluff body. These vortices propagate downstream, giving rise to periodic pressure variations which can be detected by the flow sensor. The frequency of the pressure variations is proportional to the volume flow through the pipe.
B port	Port on the MIXIT unit. The return liquid from the system is led back into the loop via the B port.
B-port orientation	The B port on a MIXIT unit will either be on the left or right side of the valve.
Building Management System (BMS)	A Building Management System (BMS) is a control system that controls and monitors a building's systems such as heating and ventilation. A BMS typically uses protocols such as BACnet and Modbus.
Controller	Using sensor inputs a controller holds the liquid temperature at a specified temperature setpoint. In MIXIT the controller is integrated.
Delta T (ΔT)	Delta T (ΔT) is the temperature difference between the supply and return liquid in a heating or cooling system.
Fieldbus	Fieldbus is a two-way communication link between devices. Fieldbus is integrated into the MIXIT unit and act as the link between MIXIT and a Building Management System. MIXIT provides all data points through one data connection and no I/O is required in the sub controller. If the integrator uses an IP-based fieldbus, the sub controller is redundant.
Firmware	Firmware is software integrated in a hardware device. The firmware is specifically designed for that piece of hardware and acts as the operating system.
Flow	Flow is the amount of liquid that passes through a pump within a certain period of time. Volume flow (Q) is the amount of liquid, the pump can move per unit time (m^3/h).
Flow temperature	The temperature of the liquid in the supply pipe in a heating or cooling system.
GENIbus	GENIbus is an open data communication protocol developed and maintained by Grundfos. It is used to connect Grundfos pumps to pump controllers or via gateways to monitoring and supervisory computers in Building Management Systems and SCADA systems.
GLoWPAN	GLoWPAN is a propriatary wireless signal developed and maintained by Grundfos.
Heat load, Φ [kW]	The amount of heat required by a heating system.
Hydraulic power	The power that the pump transfers to the liquid in the shape of flow and head.
Injection circuit, two-way valve	This injection circuit operates with a variable flow on the primary side and a constant flow on the secondary side. The circuit has a pump installed on the primary side, injecting the liquid into the heating system, while the pump on the secondary side distributes the liquid in the system.
Injection circuit, three-way valve	The injection circuit operates with a constant flow and temperature on the primary side, causing the temperature on the secondary side to increase instantly. The circuit has a pump installed on the primary side, injecting the liquid into the heating system, while the pump on the secondary side distributes the liquid in the system. In a two-way valve injection circuit, the temperature at the mixing point is controlled by opening and closing the valve. In a three-way valve injection circuit, the mixed temperature is controlled by opening and closing port A of the control valve.
K_v	K_v represents the valve capacity measured as the flow of liquid in m^3/h at a pressure differential of 1 bar across the valve, with the valve open at any position.
K_{vs}	K_{vs} is the maximum K_v value measured when the valve is fully open (100 %). For MIXIT, the K_{vs} value represent the water in m^3/h at a differential pressure of 1 bar from port A to AB. The K_{vs} value can be used to determine the size of a valve.
Mixing circuit	The basic principle of a mixing loop is to mix the primary liquid with the return liquid to obtain the required mix temperature. The mixing circuit operates with a variable flow on the primary side and a constant flow on the secondary side. Because the system in this type of application allows for variable flow, there is no primary pump.
Modbus	Modbus is a communications protocol enabling communication between devices connected to the same network.
Non-return valve	The non-return valve ensures that the liquid flows through the pipe in the correct direction where pressure conditions may otherwise cause a reversed flow.
Integrated Temperature Sensor (ITS)	A temperature sensor integrated in the MIXIT unit.

Secondary flow	The secondary flow refers to the flow in the secondary circuit of a heating or cooling system.
Secondary temperature difference	The temperature difference between the supply and return liquid in the secondary circuit of a heating or cooling system.
Settable flow range	The products working range within which a maximum flow can be set.
Valve position	LEDs on MIXIT's operating panel, indicating to what degree the valve is open.
Vortex flow sensor	A combined flow and temperature sensor integrated in the MIXIT unit.
ENeV	The Energieeinsparverordnung is a regulation in Germany describing minimum requirements regarding energy use of new and renovated buildings.

15. Grundfos Product Center

Online search and sizing tool to help you make the right choice.

From the international view, you can select your specific country to view the product range available to you.

International view: <http://product-selection.grundfos.com>

All the information you need in one place

Performance curves, technical specifications, pictures, dimensional drawings, motor curves, wiring diagrams, spare parts, service kits, 3D drawings, documents, system parts. The Product Center displays any recent and saved items - including complete projects - right on the main page.

Downloads

On the product pages, you can download installation and operating instructions, data booklets, service instructions, etc., in PDF format.

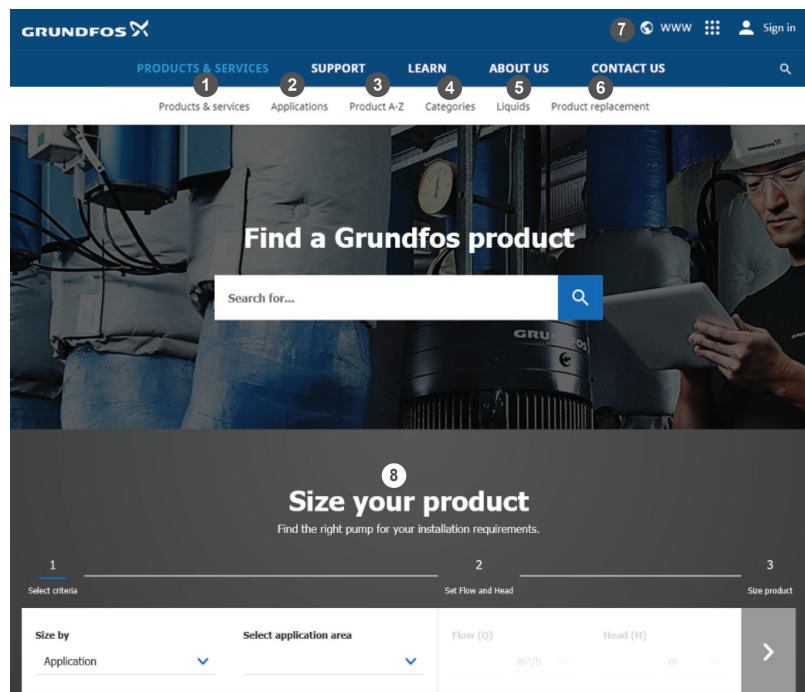
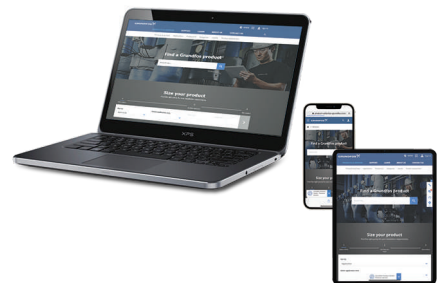

When you select your country, you will see the menus below. Note that some menus may not be available depending on the country.

Example: <https://product-selection.grundfos.com/uk>

Pos.	Description
1	Products & services enables you to find products and documents by typing a product number or name into the search field.
2	Applications enables you to choose an application to see how Grundfos can help you design and optimise your system.
3	Products A-Z enables you to look through a list of all the Grundfos products.
4	Categories enables you to look for a product category.
5	Liquids enables you to find pumps designed for aggressive, flammable or other special liquids.
6	Product replacement enables you to find a suitable replacement.
7	WWW enables you to select the country, which changes the language, the available product range and the structure of the website.
8	Sizing enables you to size a product based on your application and operating conditions.

99513565 05.2024

ECM: 1396484

GRUNDFOS Holding A/S
Poul Due Jensens Vej 7
DK-8850 Bjerringbro
Tel: +45 87 50 14 00
www.grundfos.com

GRUNDFOS 